

D-side

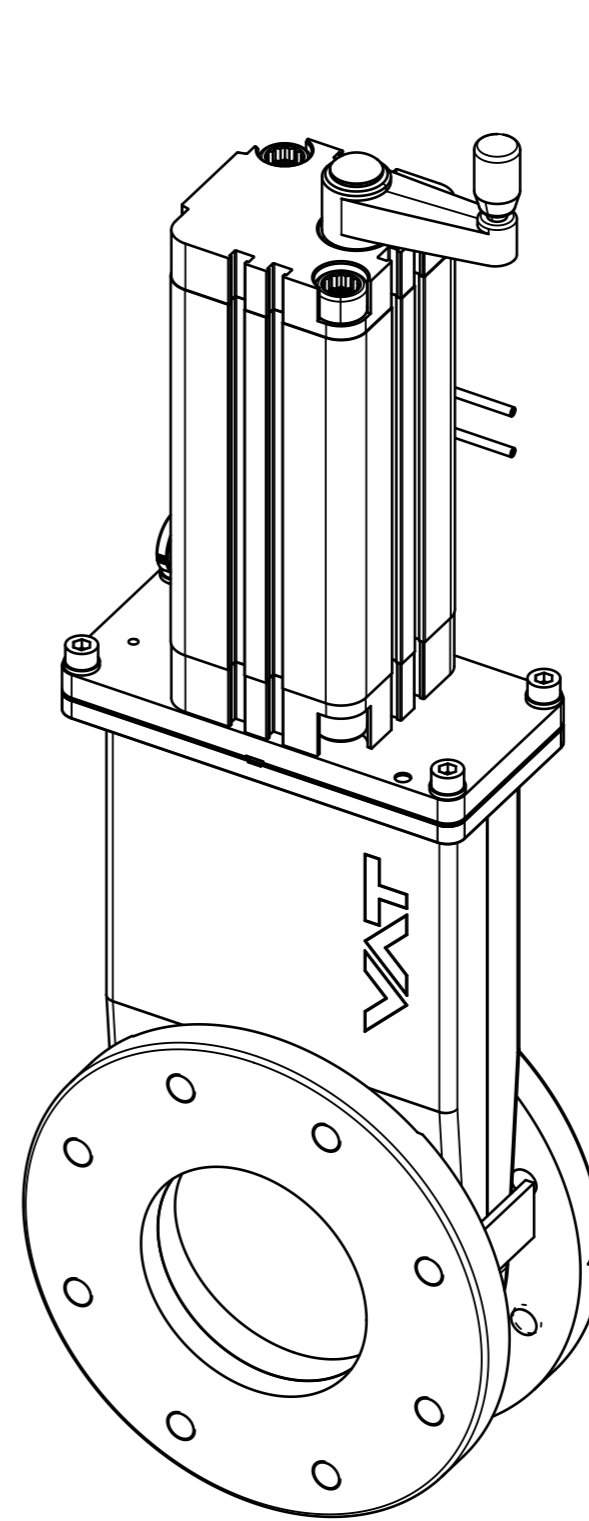

B-side

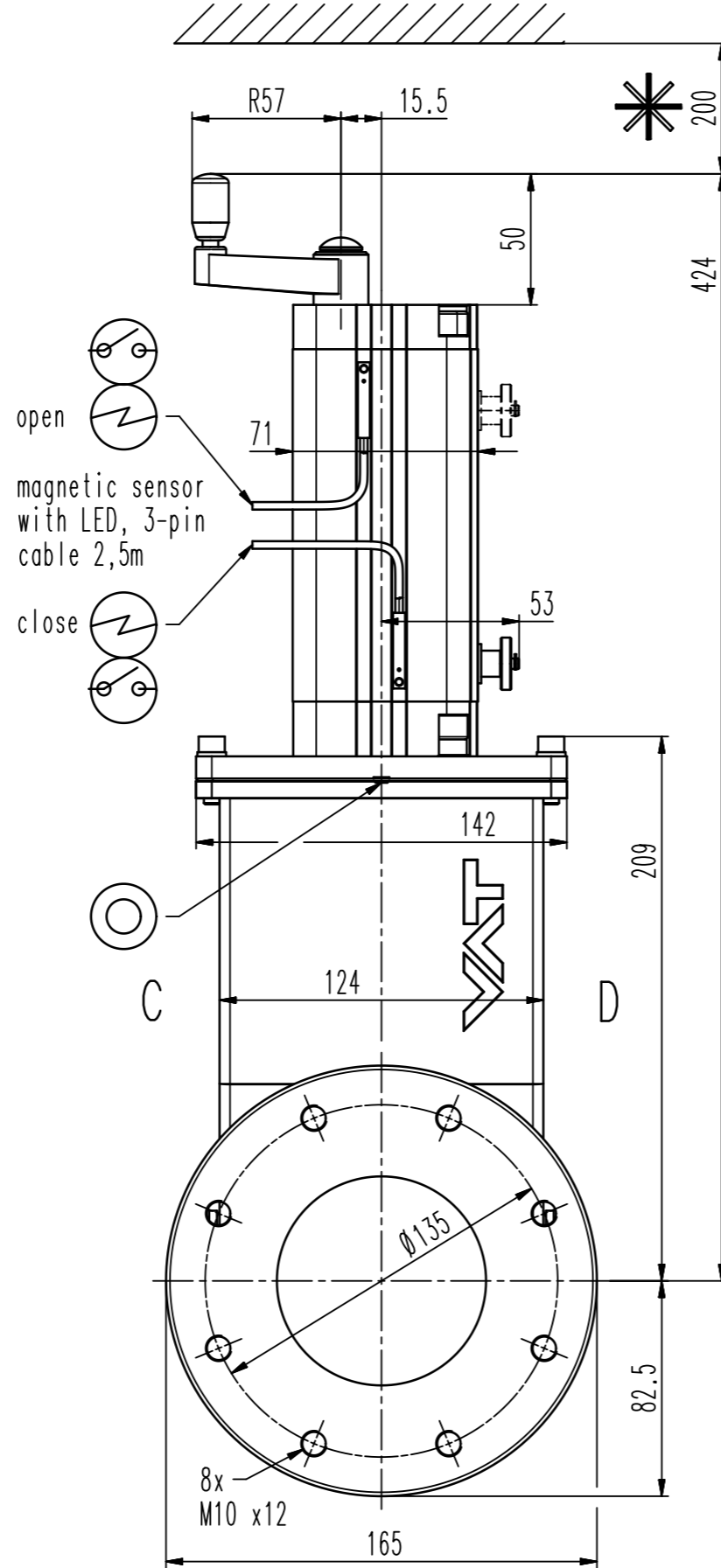
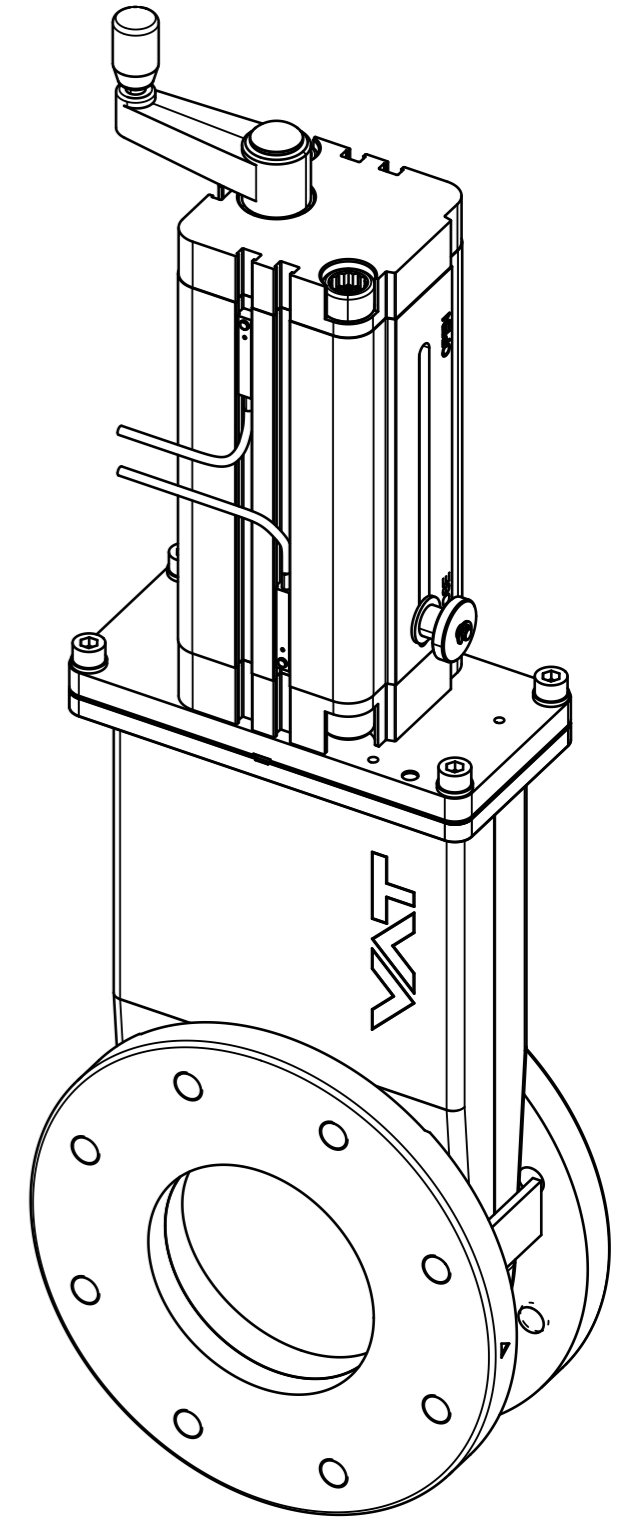

A-(seat)side

- ▼ Seat side
- ⊙ Comp. air connection
- ⊙ Electrical connection
- ⊙ Leak detection port
- ⊙ Mech. pos. indication
- ⊙ Position indicator
- ⊙ Required for dismantling
- ⊙ Emergency actuation
- ⊙ For attachment
- ⊙ Bake-out area
- ⊙ Differential pumping port

Vacuum gate valve



VAT Vakuumentile AG
 CH-9469 Haag, Switzerland
 Tel ++41 81 7716161 Fax ++41 81 7714830

Rev.-Date: 15.07.13
 Visa: HUC

Series	121	Ordering No.	09138-JE08-0001
Projection E	DN	Flange	JIS
	80	Rev.	
Dimensional Drawing	702745		