

## UHV gate valve with pneumatic actuator

This manual is valid for the valve ordering number(s):

10836- . E 14/24/34/44

10840- . E 14/24/34/44

10844- . E 14/24/34/44

10846- . E 14/24/34/44

The fabrication number is indicated on each product as per the label below (or similar):

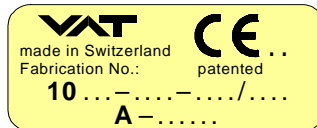

← Fabrication number

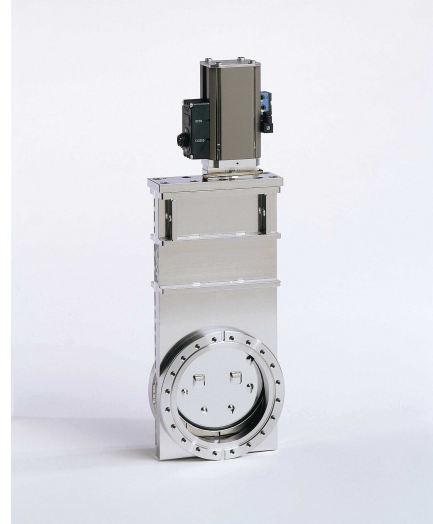

### Explanation of symbols:



Read declaration carefully before you start any other action!



Keep body parts and objects away from the valve opening!



Attention!



Hot surfaces; do not touch!



Product is in conformity with EC guidelines, if applicable!



Loaded springs and/or air cushions are potential hazards!



Disconnect electrical power and compressed air lines. Do not touch parts under voltage!



Wear gloves!



Read these «**Installation, Operating & Maintenance Instructions**» and the enclosed «**General Safety Instructions**» carefully before you start any other action!



**Imprint:**

**Manufacturer** VAT Vakuumventile AG, CH-9469 Haag, Switzerland

Website  
www.vatvalve.com

Phone  
+41 81 771 61 61

Fax  
+41 81 771 48 30

Email  
CH@vatvalve.com

**Publisher** VAT Vakuumventile AG, CH-9469 Haag, Switzerland

**Editor** VAT Vakuumventile AG, CH-9469 Haag, Switzerland

**Print** VAT Vakuumventile AG, CH-9469 Haag, Switzerland

**Copyright** © VAT Vakuumventile AG 2008

No part of these Instructions may be reproduced in any way (photocopies, microfilms or any other reproduction processes) nor may it be manipulated with electronic systems, duplicated or distributed without written permission from VAT. Offenders are liable to pay damages.

The original VAT firmware and updated state of the art versions of the VAT firmware are intended for use with VAT products. The VAT firmware contains a limited, time unlimited user license. The VAT firmware may not be used for purposes other than those intended nor is it permitted to make copies of the VAT firmware. In particular, it is strictly forbidden to give copies of the VAT firmware to other people.

The use of trade names, brand names, trademarks, etc. in these Instructions does not entitle third parties to consider these names to be unprotected and to use them freely. This is in accordance with the meaning of the laws and acts covering brand names and trademarks.



**Contents:**

1	Use of product .....	4
1.1	Technical data .....	4
2	Installation .....	4
2.1	Installation into the system .....	4
2.2	Connections .....	5
2.2.1	Compressed air connection .....	5
2.2.2	Electrical connection .....	5
3	Operation .....	6
3.1	Normal operation .....	6
3.2	Operation under increased temperature .....	6
3.3	Behavior in case of compressed air pressure drop .....	6
3.4	Behavior in case of power failure .....	6
3.5	Behavior in case of other failures .....	6
4	Trouble shooting .....	7
5	Maintenance & repairs .....	8
5.1	Replacement of actuator / mechanism assembly .....	9
5.2	Replacement of gate .....	10
6	Drawing .....	11
7	Spare parts .....	12
8	Warranty .....	14

## 1 Use of product

Use product for clean and dry indoor vacuum applications under the conditions indicated in chapter «Technical data» only! Other applications are only allowed with the written permission of VAT.

### 1.1 Technical data

Pressure range	1 x 10 <sup>-10</sup> mbar to 1.6 bar (abs)
Differential pressure on the gate	≤ 1.6 bar in either direction
Differential pressure at opening	≤ 30 mbar
Admissible temperature: Valve	≤ 250°C open, 200°C closed
Pneumatic actuator	≤ 200°C
Position indicator	≤ 80°C
Solenoid	≤ 50°C
Position indicator: contact rating	5 A / 250 V AC, 3 A / 50 V DC
Solenoid	see tag on solenoid

## 2 Installation

### 2.1 Installation into the system

#### Admissible forces

Forces from evacuating the system, from the weight of other components, and from baking can lead to deformation of the valve body and to malfunction of the valve. The stress has to be relieved by suitable means, e.g. bellows sections. The following forces are admissible:

DN (nom. I.D.)		Axial tensile or compressive force «FA»		Bending moment «M»	
mm	inch	N	lbf	Nm	lbf • ft
63	2½	2000	448	80	59
100	4	2500	560	100	74
160	6	3000	672	150	110
200	8	3000	672	150	110

If a combination of both forces («FA» and «M») occurs, the values mentioned above are invalid. Please contact VAT for more information.

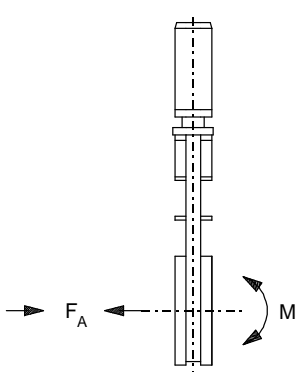

The diagram shows a vertical valve assembly. A horizontal arrow labeled  $F_A$  points to the left, representing axial force. A curved arrow labeled  $M$  indicates a bending moment around the vertical axis of the valve.

## 2.2 Connections

### 2.2.1 Compressed air connection



- Connect compressed air only if
- valve has been installed into the vacuum system
  - moving parts cannot be touched

With solenoid: Connect compressed air to **IN** (internal thread R 1/8", 1/8" NPT for USA)  
 Without solenoid: Connect compressed air to **OPEN** and **CLOSE** (internal thread 1/8")

Solenoid delivered separately:

Compressed air connection on pneumatics cylinder:  
 Internal thread 1/8" "

Remove 2 vent plugs from «A» and «B»

Compressed air to connection <A>:  
 Valve opens

Compressed air to connection <B>:  
 Valve closes

Compressed air pressure (min. - max. overpressure): 4 - 7 bar / 55 - 100 psig  
 Use only clean, dry or slightly oiled air!

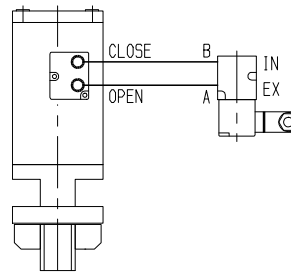

### 2.2.2 Electrical connection



Do not touch electrical parts under voltage!



- Connect electrical power only if
- valve has been installed into the vacuum system
  - moving parts cannot be touched

Verify that mains voltage matches voltage stated on the solenoid! Sockets for position indicator and solenoid are supplied with the valve.

Wire solenoid and position indicator according to the following diagrams:

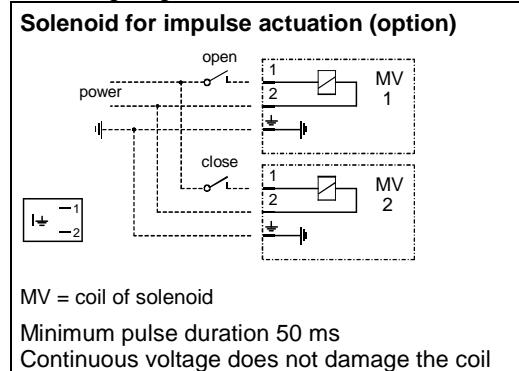
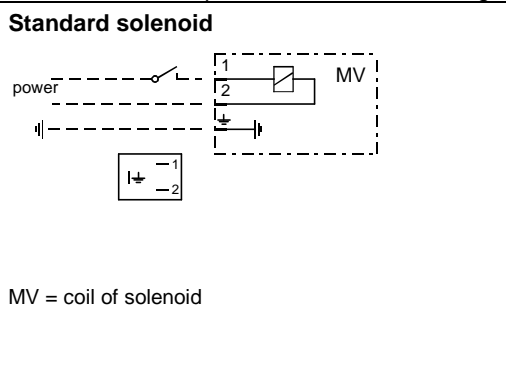

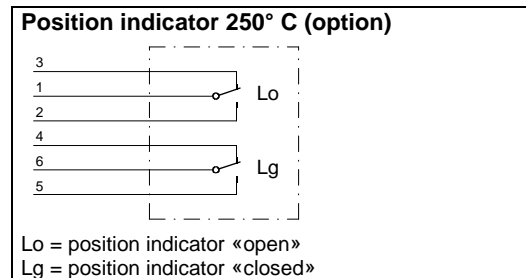
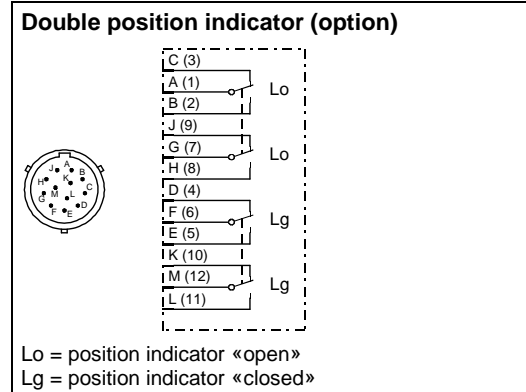
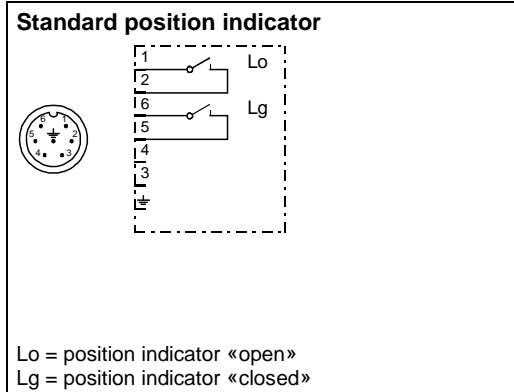

### 3 Operation

#### 3.1 Normal operation

Valve is opened and closed by means of compressed air.

#### 3.2 Operation under increased temperature

See «1.1 Technical data»

#### 3.3 Behavior in case of compressed air pressure drop

Valve closed: valve remains closed  
 Valve open: valve position is undefined

#### 3.4 Behavior in case of power failure

Standard solenoid: valve closes

Solenoid for impulse actuation (option): valve position does not change, but a started movement will be completed

#### 3.5 Behavior in case of other failures

Standard solenoid: valve closes

Solenoid for impulse actuation (option): valve position does not change, but a started movement will be completed

## Emergency operation at power failure

In case of a power failure, the valve can be actuated manually if compressed air is available.

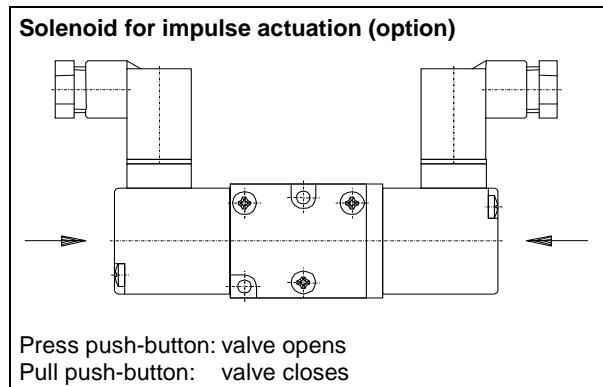
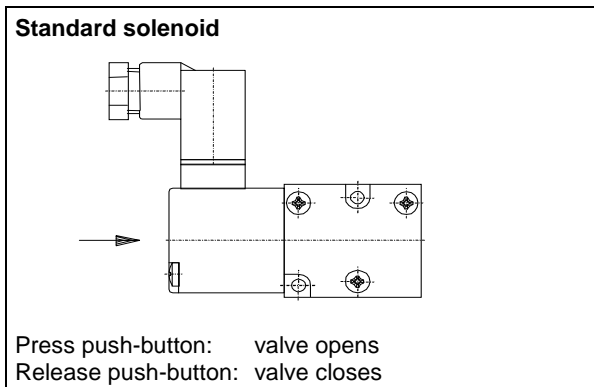

## 4 Trouble shooting

Valve does not close/open: Power available?  
Compressed air available?  
Solenoid defective?  
Check voltage!  
Check air pressure!

Leak at gate: Clean valve seat and gate!  
Replace gate, if damaged!  
Correct air pressure?

Leak at body: Flanges leaktight?  
Replace bonnet seal!

### Global leak at bonnet seal after heating the valve!

Due to a possible settlement of screw and VATSEAL it could happen that after a heat up and cool down procedure the bonnet seal becomes slight leaky. In this case please check the torque (see below) of bonnet screw (see page 11 item 61) and tighten the screws if necessary with a torque wrench.

Remark:  
Do tight screws crosswise!  
Necessary torque of screws is for  
DN63, DN100 and DN 160; 20 Nm /15 lbf · ft.  
DN200; 40 Nm / 30 lbf · ft.

If you need any further information, please contact one of our service centers. You can find the addresses on our website:  
<http://www.vat.ch>



## 5 Maintenance & repairs

Under clean operating conditions, the valve does not require any maintenance during the specified cycle life. Contamination from the process may influence the function and requires more frequent maintenance.

Before carrying out any maintenance or repairs, please contact VAT. It has to be individually decided whether the maintenance/repair can be performed by the customer or has to be carried out by VAT. The fabrication number on the valve

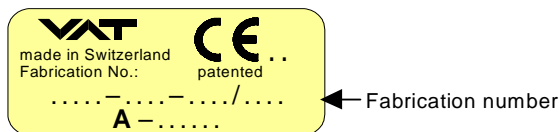

has always to be specified.

All supplies (e. g. compressed air, electrical power) must be disconnected for removal/installation of the valve from/into the system and for maintenance work.



Even with disconnected supply, loaded springs and/or air cushions in cylinders can be potential hazards.



Keep fingers and objects away from the valve opening!

Products returned to VAT must be free of harmful substances such as e.g. toxic, caustic or microbiological ones. If products are radioactively contaminated, fill in the VAT form «Contamination and Radiation Report» and send it with the product. The form is available at VAT. The maximum values indicated in the form must not be exceeded.



## 5.1 Replacement of actuator / mechanism assembly

- Vent chambers and open valve
- Disconnect compressed air and electrical power from valve
- Remove bonnet screws (61) in crosswise order
- Withdraw actuator/mechanism assembly carefully from body
- Check and clean sealing surfaces of bonnet and valve seat
- Put new bonnet seal (60) on body or bonnet (depending on mounting position). If the actuator is directed downwards, proceed according to the following drawing:
- Reassemble in reverse direction

**Note!** Tighten screws in crosswise order!

Torque: DN 63 - 160 20 Nm / 15 lbf · ft

DN 200 40 Nm / 30 lbf · ft

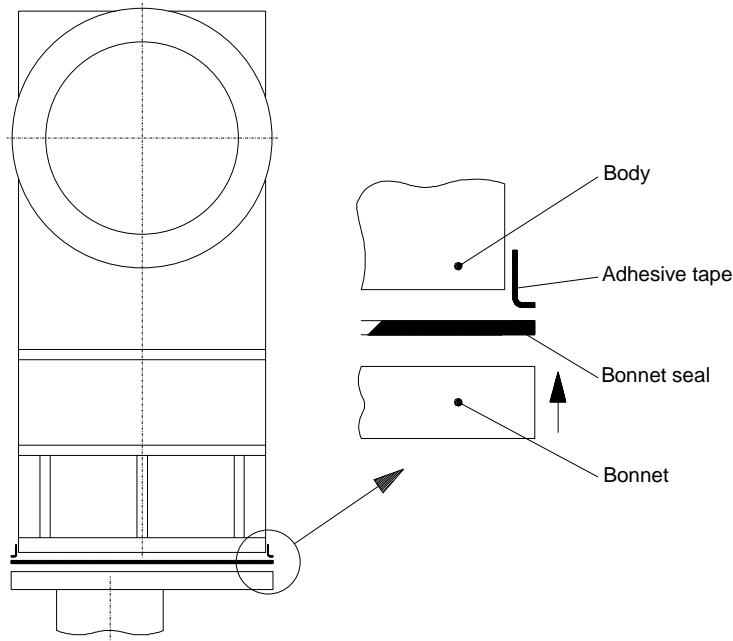

## 5.2 Replacement of gate

Remove actuator/mechanism assembly as described in the section «Replacement of actuator/mechanism assembly»

- Put mechanism into horizontal position to prevent the locking balls falling out
- Lift up valve plate manually at «H» and insert tool (W1) between spring (21/6) and ball guidance (21/3). Refer to figure 2.
- Remove gate (21/4) in direction of the arrow
- Insert new gate in reverse direction
- Remove tool (W1)
- Check whether gate is properly inserted. The markings  $\Delta$  and  $\nabla$  (W2) of ball guidance and gate must face each other.

1) Lift up the gate at „H”	2) Insert Allen-key																																		
	<table border="1" style="width: 100%; border-collapse: collapse; text-align: center;"> <tr> <td style="width: 10%;">DN</td> <td style="width: 10%;">mm</td> <td style="width: 10%;">63</td> <td style="width: 10%;">100</td> <td style="width: 10%;">160</td> <td style="width: 10%;">200</td> </tr> <tr> <td>Allen-key number</td> <td></td> <td>6</td> <td>6</td> <td>8</td> <td>10</td> </tr> <tr> <td rowspan="2" style="text-align: left;"><b>X</b></td> <td>mm</td> <td>6.0</td> <td>6.0</td> <td>8.0</td> <td>5.0</td> </tr> <tr> <td>inch</td> <td>0.16</td> <td>0.16</td> <td>0.31</td> <td>0.20</td> </tr> <tr> <td rowspan="2" style="text-align: left;"><b>Y</b></td> <td>mm</td> <td>0.0</td> <td>0.0</td> <td>7.0</td> <td>10.0</td> </tr> <tr> <td>inch</td> <td>0.0</td> <td>0.0</td> <td>0.27</td> <td>0.40</td> </tr> </table>	DN	mm	63	100	160	200	Allen-key number		6	6	8	10	<b>X</b>	mm	6.0	6.0	8.0	5.0	inch	0.16	0.16	0.31	0.20	<b>Y</b>	mm	0.0	0.0	7.0	10.0	inch	0.0	0.0	0.27	0.40
DN	mm	63	100	160	200																														
Allen-key number		6	6	8	10																														
<b>X</b>	mm	6.0	6.0	8.0	5.0																														
	inch	0.16	0.16	0.31	0.20																														
<b>Y</b>	mm	0.0	0.0	7.0	10.0																														
	inch	0.0	0.0	0.27	0.40																														
3) Remove seal plate	Use the proper Allen-key size																																		

## 6 Drawing

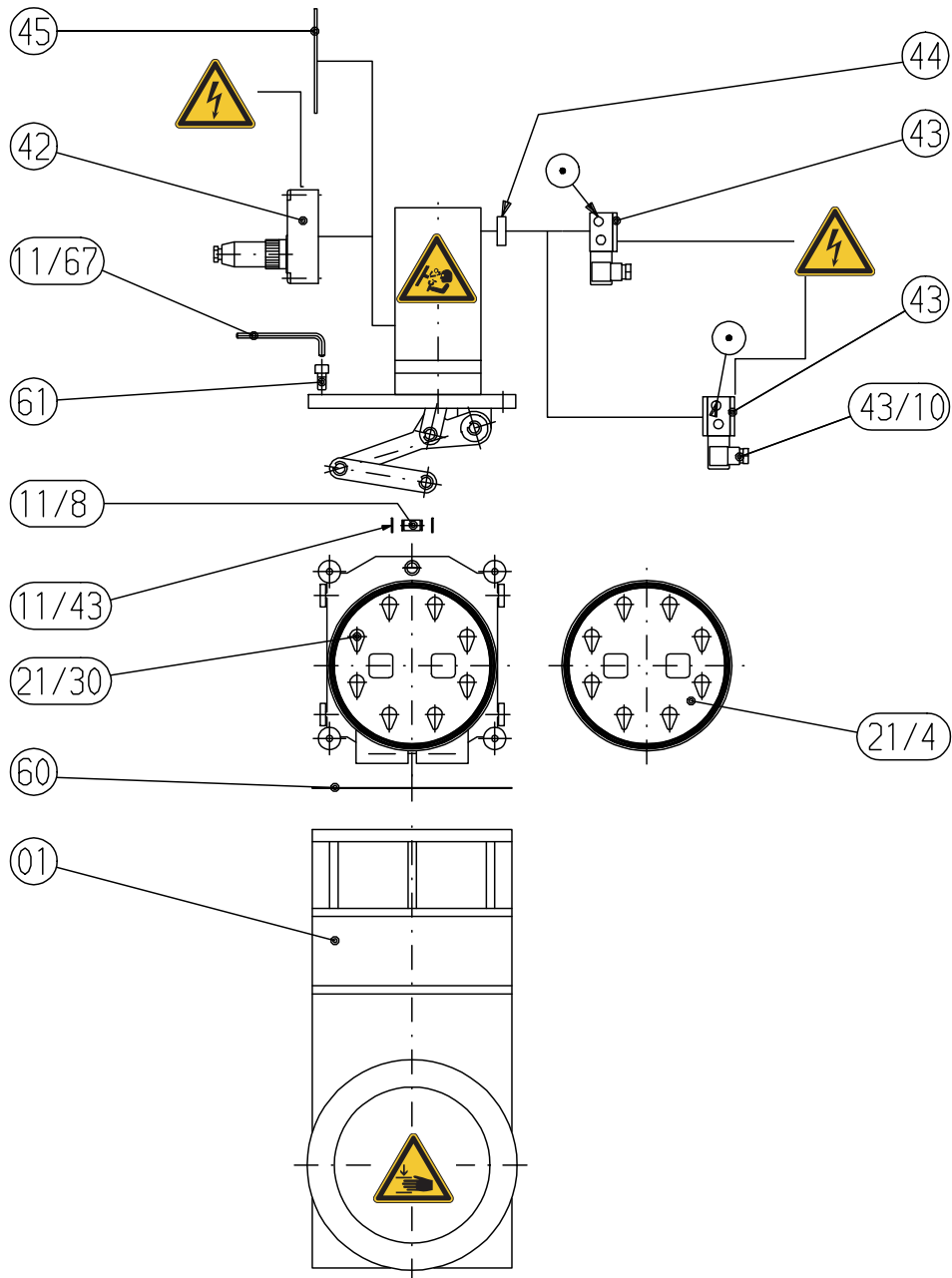

## 7 Spare parts



Please specify the **fabrication number of the valve** (see yellow label on valve) when ordering spare parts. This is to ensure that the appropriate spare parts are supplied.

Item	Description	DN	Part No.
	Seal kit, Consisting of:  - Gate /21/4) - Bonnet seal (60)	63	On request
		100	On request
		160	On request
		200	On request
21/4	Gate	63	On request
		100	On request
		160	On request
		200	On request
21/30	1 Set of locking balls	8 pcs 63	On request
		12 pcs 100	On request
		16 pcs 160	On request
		16 pcs 200	On request
60	Bonnet seal	63	On request
		100	On request
		160	On request
		200	On request

Air connection kit (standard without solenoid)				
Item	Description	DN	Qty.	Part No.
44	Pneumatic connection kit	63-200	1	On request

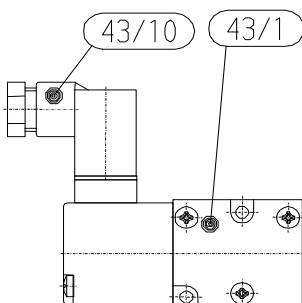
Solenoid kit: (standard)			
			
Item	Description	Qty.	Part No.
	Solenoid kit	1	On request
43/1	Solenoid	1	On request
43/10	Plug	1	On request

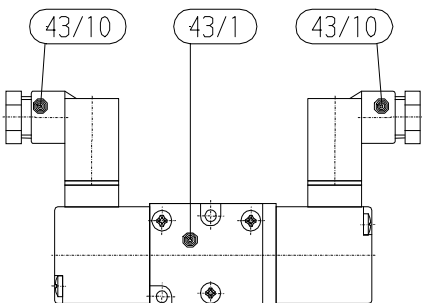
Solenoid kit: impulse actuation (option)			
			
Item	Description	Qty.	Part No.
	Solenoid kit	1	On request
43/1	Solenoid	1	On request
43/10	Plug	2	On request

**Position indicator kit: open/closed (standard)**

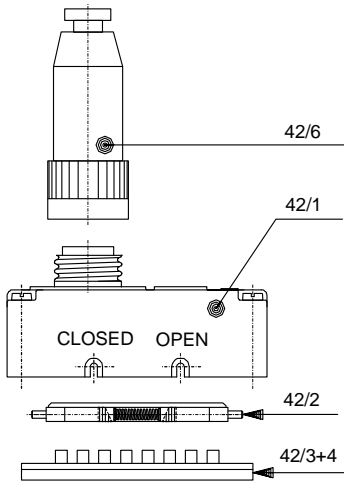

Item	Description	Qty.	Part No.
	Position indicator DN 63	1	On request
	kit DN 100	1	On request
	DN 160	1	On request
	DN 200	1	On request
42/1	Position indicator	1	On request
42/2	Slider	1	On request
42/3	Strip	1	On request
42/4	Driving pin	2	On request
42/6	Plug	1	On request

**Position indicator kit: open/closed with double position indicator (option)**

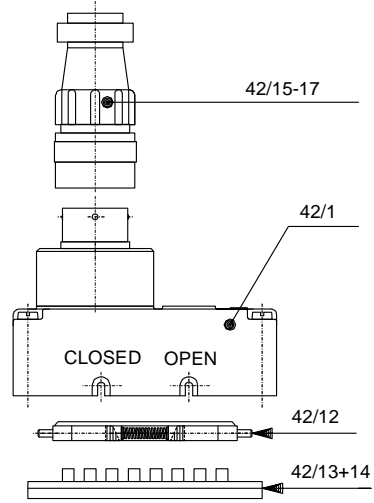

Item	Description	Qty.	Part No.
	Position indicator kit	1	On request
42/1	Position indicator	1	On request
42/12	Slider	1	On request
42/13	Strip	1	On request
42/14	Driving pin	2	On request
42/15	Bushing	12	On request
42/16	Plug	1	On request
42/17	Cable strain relief	1	On request

**Position indicator kit 250° C (option)**

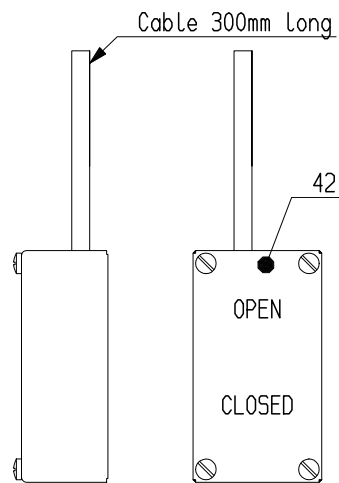

Item	Size of valve	Qty.	Part No.
42	DN 63	1	On request
42	DN 100	1	On request
42	DN 160	1	On request
42	DN 200	1	On request



## 8 Warranty

Each product sold by VAT Vakuumventile AG (VAT) is warranted to be free from the manufacturing defects that adversely affect the normal functioning thereof during the warranty period stated in VAT's «Terms of Sale» immediately following delivery thereof by VAT, provided that the same is properly operated under conditions of normal use and that regular, periodic maintenance and service is performed or replacements made, in accordance with the instructions provided by VAT. The foregoing warranty shall not apply to any product or component that has been repaired or altered by anyone other than an authorized VAT representative or that has been subject to improper installation or abuse, misuse, negligence or accident. VAT shall not be liable for any damage, loss, or expense, whether consequential, special, incidental, direct or otherwise, caused by, arising out of or connected with the manufacture, delivery (including any delay in or failure to deliver), packaging, storage or use of any product sold or delivered by VAT shall fail to conform to the foregoing warranty or to the description thereof contained herein, the purchaser thereof, as its exclusive remedy, shall upon prompt notice to VAT of any such defect or failure and upon the return of the product, part or component in question to VAT at its factory, with transportation charges prepaid, and upon VAT's inspection confirming the existence of any defect inconsistent with said warranty or any such failure, be entitled to have such defect or failure cured at VAT's factory and at no charge therefor, by replacement or repair of said product, as VAT may elect. VAT MAKES NO WARRANTY OR REPRESENTATION OF ANY KIND, EXPRESS OR IMPLIED, (INCLUDING NO WARRANTY OR MERCHANTABILITY), EXCEPT FOR THE FOREGOING WARRANTY AND THE WARRANTY THAT EACH PRODUCT SHALL CONFORM TO THE DESCRIPTION THEREOF CONTAINED HEREIN, and no warranty shall be implied by law.

Furthermore, the «Terms of sale» at the back of the price list are applicable.