



## UHV gate valve with 3 position pneumatic actuator

This manual is valid for the valve ordering numbers:

10836- . E28/48

10840- . E28/48

10844- . E28/48

10846- . E28/48

The respective product identification is given on each valve in the following or in a similar way:

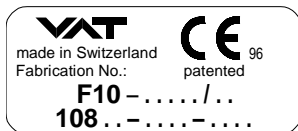

Explanation of symbols:



Read declaration carefully before you start any other action!



Keep body parts and objects away from the valve opening!



Attention!



Hot surfaces; do not touch!



Product is in conformity with EC guidelines, if applicable!



Loaded springs and/or air cushions are potential hazards!



Disconnect electrical power and compressed air lines. Do not touch parts under voltage!



Wear gloves!



Read these «**Installation, Operating & Maintenance Instructions**» and the enclosed «**General Safety Instructions**» carefully before you start any other action!



## Installation, Operating, and Maintenance Instructions Series 10.8, DN 63 - 200 (2½" - 8")

---

Imprint:

**Manufacturer** VAT Vakuumventile AG, CH-9469 Haag, Switzerland

Website  
www.vatvalve.com

Phone  
+41 81 771 61 61

Fax  
+41 81 771 48 30

Email  
CH@vatvalve.com

**Publisher** VAT Vakuumventile AG, CH-9469 Haag, Switzerland

**Editor** VAT Vakuumventile AG, CH-9469 Haag, Switzerland

**Print** VAT Vakuumventile AG, CH-9469 Haag, Switzerland

**Copyright** © VAT Vakuumventile AG 2008

No part of these Instructions may be reproduced in any way (photocopies, microfilms or any other reproduction processes) nor may it be manipulated with electronic systems, duplicated or distributed without written permission from VAT. Offenders are liable to pay damages.

The original VAT firmware and updated state of the art versions of the VAT firmware are intended for use with VAT products. The VAT firmware contains a limited, time unlimited user license. The VAT firmware may not be used for purposes other than those intended nor is it permitted to make copies of the VAT firmware. In particular, it is strictly forbidden to give copies of the VAT firmware to other people.

The use of trade names, brand names, trademarks, etc. in these Instructions does not entitle third parties to consider these names to be unprotected and to use them freely. This is in accordance with the meaning of the laws and acts covering brand names and trademarks.

## Intended use of product

Use product for vacuum applications under the conditions indicated in the chapter «Technical data» only! Other applications are only allowed with the written permission of VAT.

## Technical data

Pressure range	1 x 10 <sup>-10</sup> mbar to 1.6 bar (abs)
Differential pressure on the gate	≤ 1.6 bar in either direction
Differential pressure at opening	≤ 30 mbar
Admissible temperature: Valve	≤ 250°C open, 200°C closed
Pneumatic actuator	≤ 200°C
Position indicator	≤ 80°C
Solenoid	≤ 50°C
Position indicator: contact rating	5 A / 250 V AC, 3 A / 50 V DC
Solenoid	see tag on solenoid

## Installation into the vacuum system

The valve seat side is indicated by the symbol "∇" on the connection flange.

## Admissible forces

Forces from evacuating the system, from the weight of other components, and from baking can lead to deformation of the valve body and to malfunction of the valve. The stress has to be relieved by suitable means, e.g. bellows sections. The following forces are admissible:

DN (nom. I.D.)		Axial tensile or compressive force «FA»		Bending moment «M»	
mm	inch	N	lbf	Nm	lbf • ft
63	2½	2000	448	80	59
100	4	2500	560	100	74
160	6	3000	672	150	110
200	8	3000	672	150	110

If a combination of both forces («FA» and «M») occurs, the values mentioned above are invalid. Please contact VAT for more information.

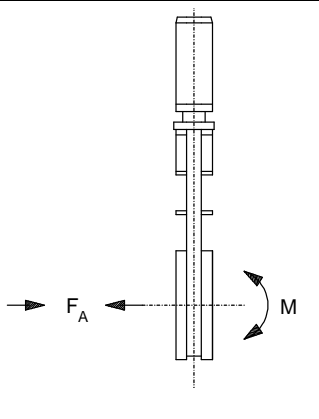

The diagram shows a vertical cross-section of a valve body. A horizontal arrow labeled  $F_A$  points to the left, representing axial force. A curved arrow labeled  $M$  indicates a bending moment around the vertical axis.

### Compressed air connection



Connect compressed air only if

- valve has been installed into the vacuum system
- moving parts cannot be touched

With solenoid: Connect compressed air to **IN** (internal thread R 1/8", 1/8" NPT for USA)  
 Without solenoid: Connect compressed air to **OPEN** and **CLOSE** (internal thread 1/8")

Compressed air pressure (min. - max. overpressure): 4 - 7 bar / 55 - 100 psig

Use only clean, dry or slightly oiled air!

### Electrical connection



Do not touch electrical parts under voltage!



Connect electrical power only if

- valve has been installed into the vacuum system
- moving parts cannot be touched

Verify that mains voltage matches voltage stated on the solenoid! Sockets for position indicator and solenoid are supplied with the valve.

Wire solenoid and position indicator according to the following diagrams:

**Standard solenoids**

Main cylinder MV1 and auxiliary cylinder MV2 for third position  
(see drawing on page 5)

MV = coils of solenoid

Solenoid	MV1	MV2
Valve position:		
open	1	1
Intermediate position	1	0
closed	0	1

1 = coil of solenoid supplied with current  
 0 = coil of solenoid **not** supplied with current

**Position indicator for three positions**

Lo = position indicator «open»  
 Lg = position indicator «closed»  
 Lz = position indicator for the intermediate position

## Operation

### Normal operation

Valve is opened and closed by means of compressed air.

### Admissible temperature

See «Technical data»!

### Compressed air failure

Valve closed:  
valve remains closed

Valve open:  
Valve position is undefined, depending on mounting

Valve intermediate position:  
Valve position is undefined, depending on mounting position

At compressed air return, the valve gate moves to the present position.

### Power failure

Standard solenoid: valve closes

### Emergency operation at power failure

In case of a power failure, the valve can be actuated manually if compressed air is available.

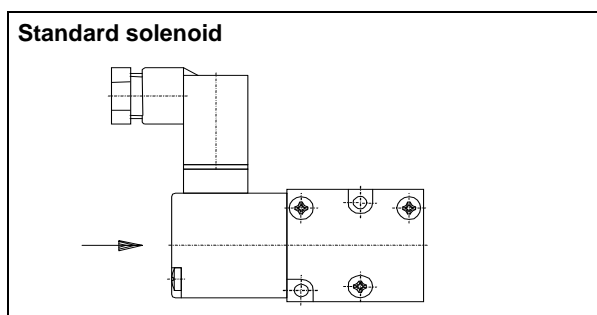

Press both push-buttons MV1 + MV2: valve opens  
 Release both push-buttons MV1 + MV2: valve closes  
 Press only push-button MV1:  
 Valve gate moves to the intermediate position

**Conversion from double acting to 3-position pneumatic actuator**

(see drawing below)

1. Vent chambers and open valve
2. Disconnect compressed air and electrical supply from valve
3. Remove position indicator (1)
4. Remove screws (23) and cylinder cover (22)  
(old cylinder cover and old position indicator are no longer used)
5. Remove nut (24, transport safety device) and screws (28) from 3-position pneumatic actuator and withdraw shaft extension (29) carefully  
**Attention:** Do not disassemble unit!
6. Screw shaft extension (29) into shaft (31) by turning at the square section (30), and tighten it
7. Put complete unit on cylinder (20) and tighten screws (28)
8. Screw on new position indicator for 3-position pneumatic actuator (old cylinder cover and old position indicator are no longer used)
9. Insert position indicator actuator (21) and position indicator strip (26) into groove and screw on cover plate (25)  
**Attention:** Leaf spring (27) must be inserted!
10. Connect compressed air and electrical power supply
11. Set desired intermediate position by means of the setscrew (8)

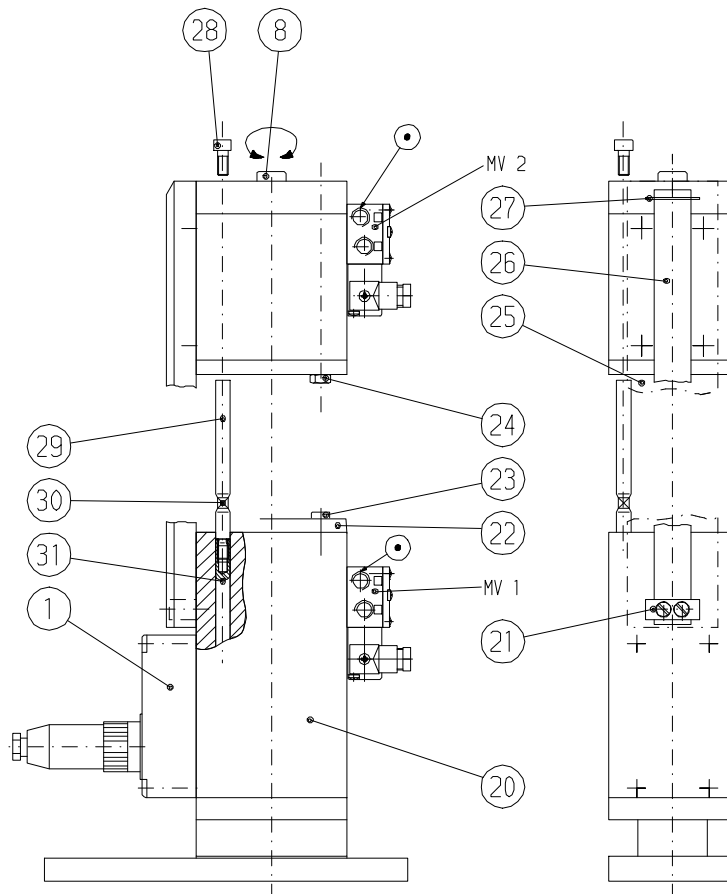



## Conversion of a manual actuator to a 3-position pneumatic actuator

(see following drawing)

### 1. Disassembly of manual actuator

- 1.1 Vent chambers and open valve
- 1.2 Loosen screw (35) through access hole (37)
- 1.3 Remove screws (33)
- 1.4 Withdraw manual actuator (36) carefully

### 2. Assembly of actuator unit «A»:

- 2.1 Valve is in open position
- 2.2 Remove nuts (34)
- 2.3 Remove cylinder cover (22) and screws (23), but do not remove O-ring from cover  
**Attention!** Do not disassemble remaining unit
- 2.4 Remove guiding shafts (31) from unit «A» and insert them into the bellows end piece (38) of the valve by turning at the squared sections (39)
- 2.5 Put actuator unit (A) in place
- 2.6 Tighten screw of piston (32) until resistance is noticeable
- 2.7 Put cylinder cover (22) in place and fix it by means of screws (23)
- 2.8 Close valve by means of compressed air (approx. 3 bar)
- 2.9 Disconnect compressed air supply and vent cylinder interior completely
- 2.10 Remove cylinder cover (22)
- 2.11 Tighten screw of piston (32) until valve unlocks (audible)
- 2.12 Loosen screw of piston (32) by ½ turn
- 2.13 Put cylinder cover (22) in place and fix it by means of screws (23)
- 2.14 Close valve by means of compressed air (approx. 3 bar) (Lever audible over dead center)
- 2.15 Measure opening pressure (should be between 1.0 and 1.3 bar in order to keep the valve locked position in the event of compressed air failure)
- 2.16 If the opening pressure is below 1.0 bar: Loosen screw of piston (32) by 1/8 turn
- 2.17 If the opening pressure exceeds 1.3 bar: Tighten screw of piston (32) by 1/8 turn
- 2.18 **Attention!** Before disassembling the cylinder cover always disconnect compressed air supply and vent cylinder interior completely

### 3. Assembly of 3-position pneumatic actuator «B»:

- 3.1 Remove cylinder cover (22) (is no longer necessary)
- 3.2 Remove nuts (24, transport safety screws) and screws (28) from 3-position pneumatic actuator and withdraw shaft extension (29)  
**Attention!** Do not disassemble unit
- 3.3 Insert shaft extensions (29) into shafts (31) by turning at the squared sections (30) and tighten them
- 3.4 Put complete unit (B) on cylinder (20) and tighten screws (28). Make sure that the O-ring (40) has been installed.
- 3.5 Connect compressed air and power
- 3.6 Adjust desired intermediate position by means of screw (8)

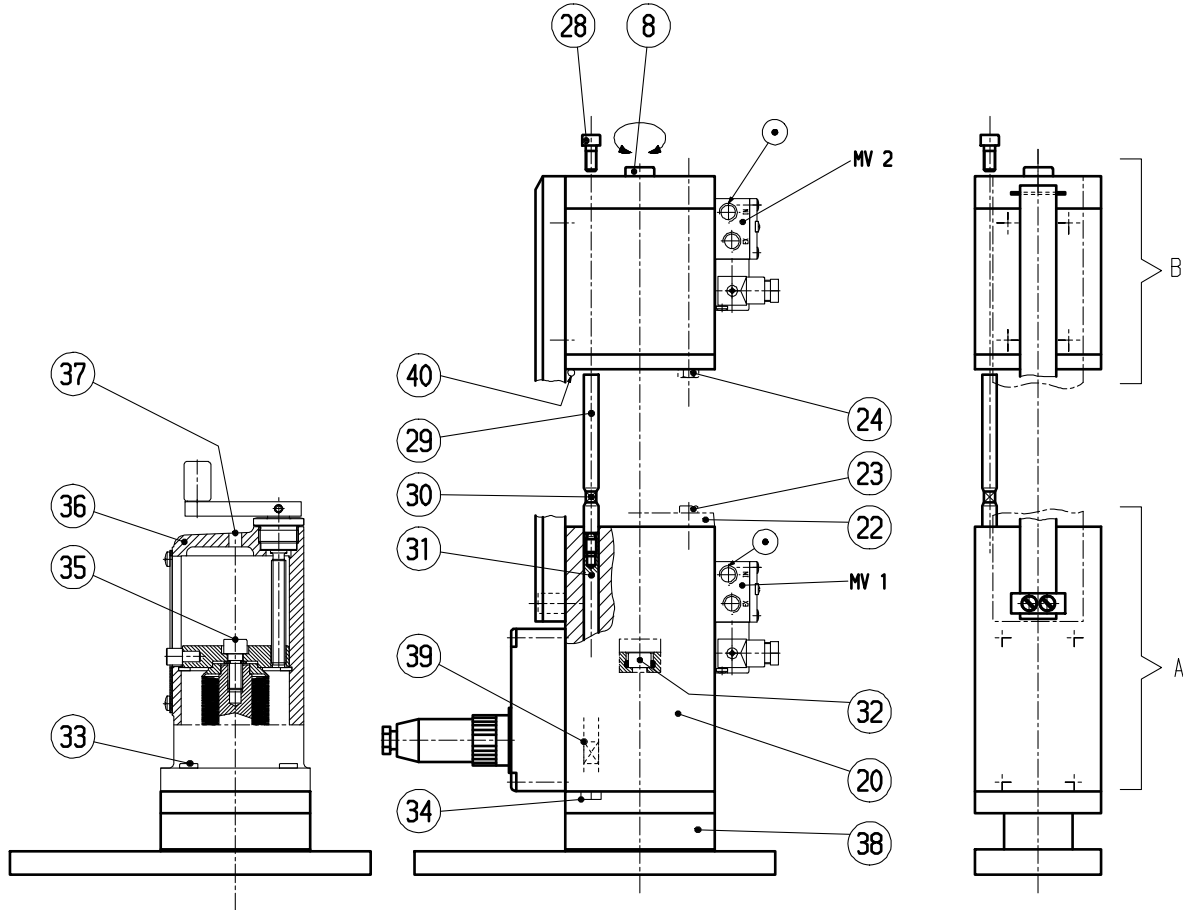

**Adjustment of the intermediate position**

<p>a) <u>with</u> solenoids:</p> <ul style="list-style-type: none"> <li>- MV1: coils of solenoids supplied with electrical power</li> <li>- MV2: coils of solenoids not supplied with electrical power</li> <li>- Adjust the desired intermediate position by means of the adjustment screw (8)</li> </ul>	<p>b) <u>without</u> solenoids:</p> <ul style="list-style-type: none"> <li>- Cylinder «A»: compressed air to «OPEN»</li> <li>- Cylinder «B»: compressed air to «MID»</li> <li>- Adjust the desired intermediate position by means of the adjustment screw (8)</li> </ul>
--	--

**Attention:** If the compressed air pressure applied for adjusting the intermediate position differs from that specified in the chapter «Compressed air pressure» (page 2) it may happen that the carrier nut inside the actuator disengages from the adjustment screw (8). The same problem can occur when the adjustment screw (8) is still being turned in counter-clockwise direction after the mechanism has reached the closed position.

In order to recapture the carrier nut, please follow the instructions below:

1. Supply the inlet «OPEN» with 1 bar / 15 psig of compressed air
2. Turn the adjustment screw (8) in clockwise direction until the carrier nut is completely recaptured (We recommend to carry out 20 full turns!)
3. Adjust the intermediate position according to above instructions [ a) or b) ]



## Preventive maintenance

Under clean operating conditions, the valve does not require any maintenance during the specified cycle life.

## Maintenance

### Replacement of actuator/mechanism assembly

The figures in brackets refer to the drawing on page 11

- Vent chambers and open valve
- Disconnect compressed air and electrical power from valve
- Remove bonnet screws (61) in crosswise order
- Withdraw actuator/mechanism assembly carefully from body
- Check and clean sealing surfaces of bonnet and valve seat
- Put new bonnet seal (60) on body or bonnet (depending on mounting position). If the actuator is directed downwards, proceed according to the following drawing:
- Reassemble in reverse direction

**Note!** Tighten screws in crosswise order!

Torque: DN 63 - 160	20 Nm / 15 lbf · ft
DN 200	40 Nm / 30 lbf · ft

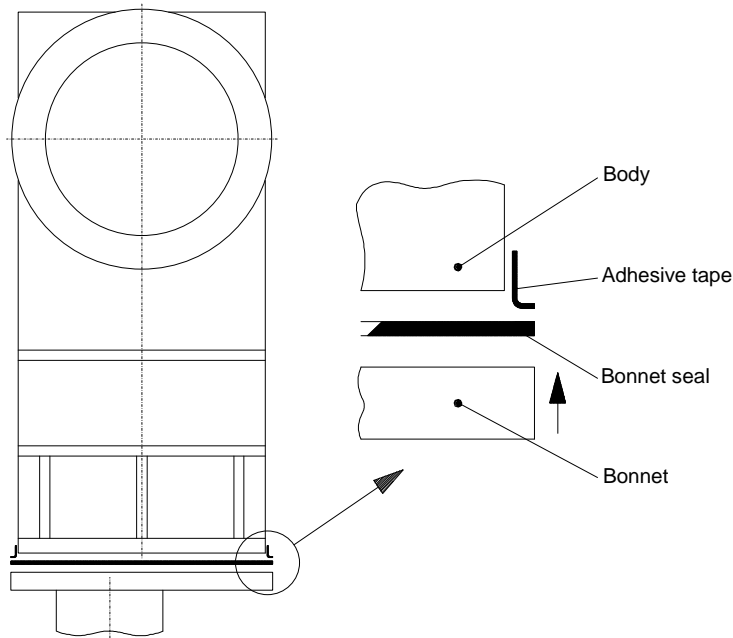

**Replacement of gate**

- Remove actuator/mechanism assembly as described in the section «Replacement of actuator/mechanism assembly»
- Put mechanism into horizontal position to prevent the locking balls from falling out
- Lift plate manually at «H» and insert tool (W1) [e.g. a screw driver] between spring (21/6) and ball guidance (21/3)
- Remove gate (21/4) in direction of the arrow
- Insert new gate in reverse direction
- Remove tool (W1)
- Check whether gate is inserted properly. The markings  $\Delta$  and  $\nabla$  (W2) on ball guidance and gate must face each other.

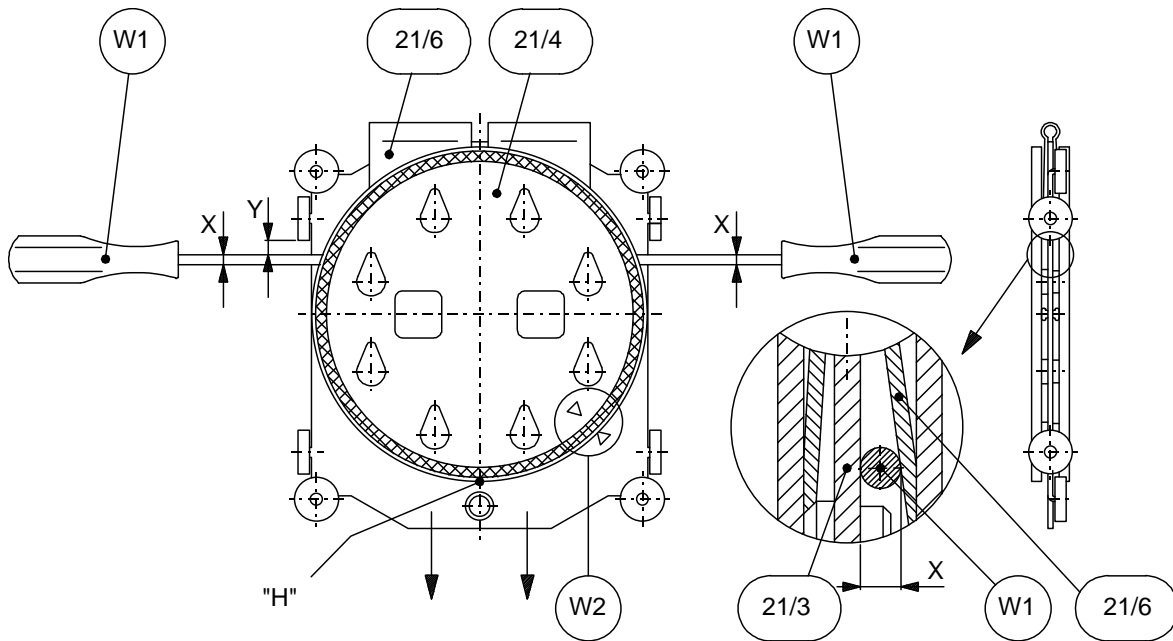

DN	mm inch	63 2½	100 4	160 6	200 8
X	mm inch	4.0 0.16	4.0 0.16	8.0 0.31	5.0 0.20
Y	mm inch	0.0 0.0	0.0 0.0	7.0 0.27	10.0 0.40

### Spare parts

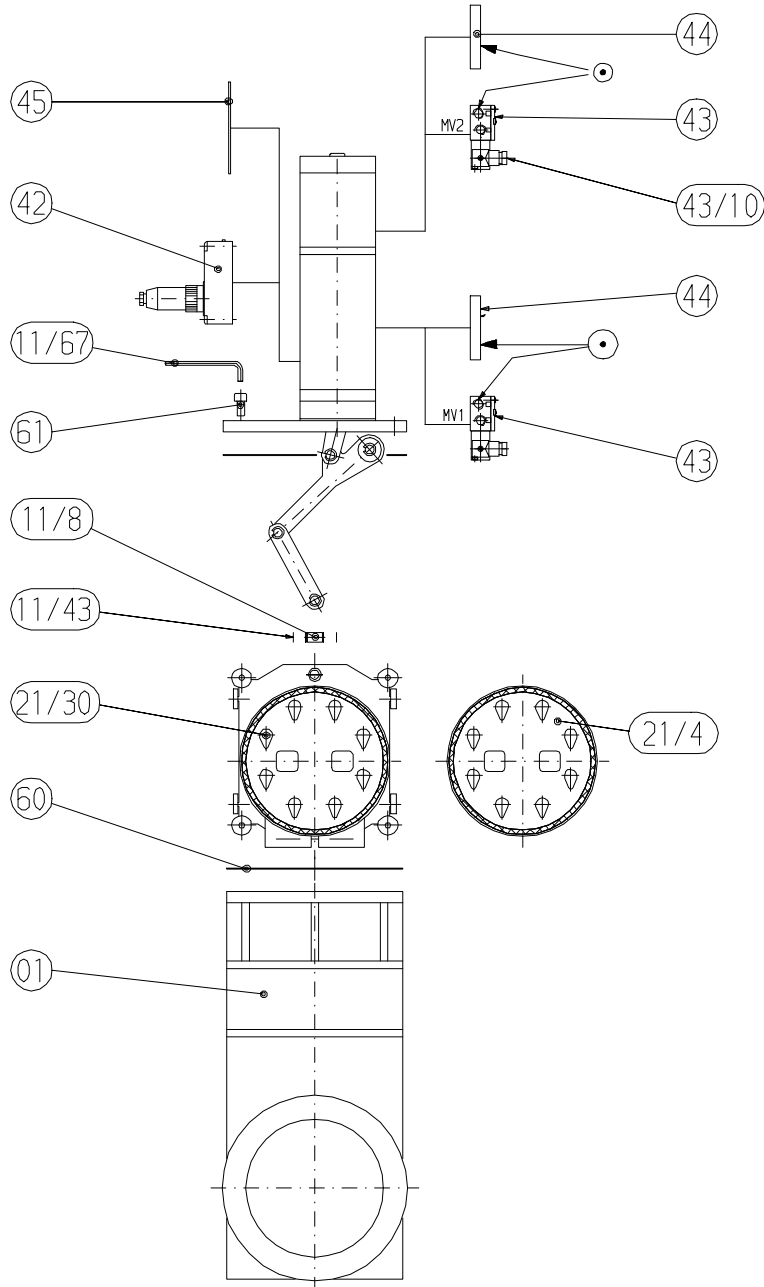

The item numbers refer to the drawing on page 11

Item	Description	DN	Part No.
	Seal kit, Consisting of:  - Gate /21/4) - Bonnet seal (60)	63	82484-R1
		100	82485-R1
		160	82486-R1
		200	82487-R1
21/4	Gate	63	84065-R1
		100	80506-R1
		160	80510-R1
		200	79324-R1
21/30	1 Set of locking balls	8 pcs	63 331584
		12 pcs	100 331587
		16 pcs	160 331589
		16 pcs	200 329723
60	Bonnet seal	63	63215-01
		100	63216-01
		160	93160-01
		200	63217-01

Air connection kit (standard without solenoid)				
Item	Description	DN	Qty.	Part No.
44	Pneumatic connection kit	63-200	1	94827-R1

Solenoid kit: (standard)			
Item	Description	Qty.	Part No.
	Solenoid kit	1	94800-R1
43/1	Solenoid	1	N-7557-018 *)
43/10	Plug	1	N-8501-400

Solenoid kit: impulse actuation (option)			
Item	Description	Qty.	Part No.
	Solenoid kit	1	94801-R1
43/1	Solenoid	1	N-7557-021 *)
43/10	Plug	2	N-8501-400

..... \*) **Specify voltage!**  
(e.g. N-7557-018-**220V 50Hz**)

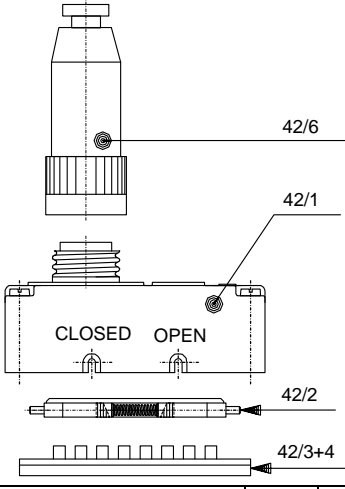
<b>Position indicator kit: 3 positions</b>			
			
Item	Description	Qty.	Part No.
	Position indicator DN 63	1	81085-R1
	kit DN 100	1	81085-R1
	DN 160	1	81085-R1
	DN 200	1	81085-R1
42/1	Position indicator	1	73656-R1
42/2	Slider	1	73638-R1
42/3	Strip	1	70987-01
42/4	Driving pin	2	70988-01
42/6	Plug	1	N-8504-002

## Trouble shooting

Valve does not close/open: Power available?  
 Compressed air available?  
 Solenoid defective?  
 Check voltage!  
 Check air pressure!

Leak at gate: Clean valve seat and gate!  
 Replace gate, if damaged!  
 Correct air pressure?

Leak at body: Flanges leaktight?  
 Replace bonnet seal!

## Repairs

Contact VAT for repairs or maintenance. The fabrication No. (F10- . . . . . / . . ) marked on the valve body has always to be specified. It has to be individually decided whether the work can be performed by the customer or has to be carried out by VAT.

All supplies (e. g. compressed air, electrical power) have to be disconnected for removal/installation of the valve from/into the system.



Even with disconnected supply, loaded springs and/or air cushions in cylinders can be potential hazards.



Keep fingers and objects away from the valve opening!

Products returned to VAT for repair have to be free of harmful substances such as e.g. toxic, caustic or microbiological ones. For radioactively contaminated products the customer has to fill in the VAT form «Contamination and Radiation Report» and to send it with the product. The form is available at VAT. The maximum permissible values indicated in the form must not be exceeded.

## Warranty

Each product sold by VAT Vakuumventile AG (VAT) is warranted to be free from the manufacturing defects that adversely affect the normal functioning thereof during the one-year period immediately following delivery thereof by VAT, provided that the same is properly operated under conditions of normal use and that regular, periodic maintenance and service is performed or replacements made, in accordance with the instructions provided by VAT. The foregoing warranty shall not apply to any product or component that has been repaired or altered by anyone other than an authorized VAT representative or that has been subject to improper installation or abuse, misuse, negligence or accident. VAT shall not be liable for any damage, loss, or expense, whether consequential, special, incidental, direct or otherwise, caused by, arising out of or connected with the manufacture, delivery (including any delay in or failure to deliver), packaging, storage or use of any product sold or delivered by VAT shall fail to conform to the foregoing warranty or to the description thereof contained herein, the purchaser thereof, as its exclusive remedy, shall upon prompt notice to VAT of any such defect or failure and upon the return of the product, part or component in question to VAT at its factory, with transportation charges prepaid, and upon VAT's inspection confirming the existence of any defect inconsistent with said warranty or any such failure, be entitled to have such defect or failure cured at VAT's factory and at no charge therefor, by replacement or repair of said product, as VAT may elect. VAT MAKES NO WARRANTY OR REPRESENTATION OF ANY KIND, EXPRESS OR IMPLIED, (INCLUDING NO WARRANTY OR MERCHANTABILITY), EXCEPT FOR THE FOREGOING WARRANTY AND THE WARRANTY THAT EACH PRODUCT SHALL CONFORM TO THE DESCRIPTION THEREOF CONTAINED HEREIN, and no warranty shall be implied by law.

Furthermore, the «Terms of sale» at the back of the price list are applicable.