



VAT Vakuumventile AG
CH-9469 Haag, Schweiz

Product data sheet

UHV gate valve, Series 108, DN 160 (ID 6'')
Ordering No. 10844-CE34

Description

Flange	CF-F 160
Actuator	pneumatic, double acting – with solenoid valve
Feedthrough	Bellows

Technical data

Leak rate	– Valve body	$< 5 \cdot 10^{-10}$ mbar ls ⁻¹
	– Valve seat	$< 1 \cdot 10^{-9}$ mbar ls ⁻¹
Pressure range		$1 \cdot 10^{-10}$ mbar to 1.6 bar (abs)
Differential pressure on the gate		≤ 1.6 bar
Differential pressure at opening		≤ 30 mbar
Conductance (molecular flow)		5880 ls ⁻¹
Cycles until first service		50 000 (unheated and under clean conditions)
Temperature	– Valve Body	≤ 250 °C open / ≤ 200 °C closed (bake-out max. 24h)
(Maximum values: depending on operating conditions and sealing materials)	– Actuator	≤ 200 °C
	– Solenoid valve	≤ 50 °C
Heating and cooling rate		50 °C h ⁻¹
Material (main components)	– Valve Body	AISI 304 (1.4301)
	– Mechanism	AISI 316L (1.4404), AISI 304 (1.4301)
	– Bellows	AISI 316L (1.4404, 1.4435)
Seal	– Bonnet	metal
	– Gate	FKM (Viton®), vulcanized
	– Actuator	FKM (Viton®), NBR
Mounting position		any
Volume of pneumatic actuator		0.14 l / 0.0049 ft ³
Compressed air		4 – 7 bar / 58 – 102 psi
min. – max. overpressure		
Compressed air connection		G $\frac{1}{8}$ " (1/8" NPT for USA)

Created by: MAEM	Release date: 2013-01-17	1 of 2
Modified by:	Release date:	299111EA



VAT Vakuumventile AG
CH-9469 Haag, Schweiz

Product data sheet

UHV gate valve, Series 108, DN 160 (ID 6'')
Ordering No. 10844-CE34

Actuation time	- closing	1.5 s
	- opening	1.5 s
Weight		16.6 kg / 36.6 lbs
Behavior in case of compressed air pressure drop	- Valve closed	valve remains closed
	- Valve open	undefined
Behavior in case of power failure	- Valve closed	valve remains closed
	- Valve open	valve closes

Electrical connections

Solenoid valve

Type	4/2 way
Voltage	Defined by order

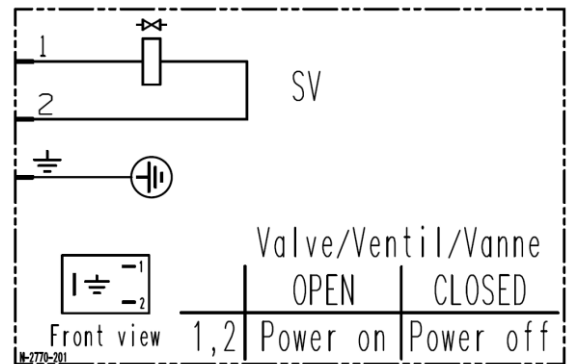

Wiring diagram

Created by: MAEM	Release date: 2013-01-17	2 of 2
Modified by:	Release date:	299111EA