

Vacuum gate valve with pneumatic actuator

This manual is valid for the valve ordering number(s):
12146-. A01
12148-. A01

The fabrication number is indicated on each product as per the label below (or similar):

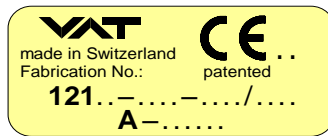

← Fabrication number

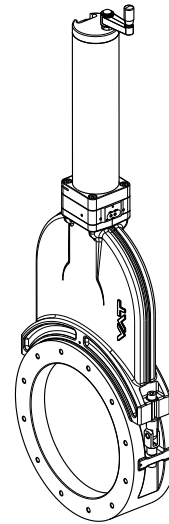

Explanation of symbols:



Read declaration carefully before you start any other action!



Keep body parts and objects away from the valve opening!



Attention!



Hot surfaces; do not touch!



Product is in conformity with EC guidelines, if applicable!



Loaded springs and/or air cushions are potential hazards!



Disconnect electrical power and compressed air lines. Do not touch parts under voltage!



Wear gloves!



Read these «**Installation, Operating & Maintenance Instructions**» and the enclosed «**General Safety Instructions**» carefully before you start any other action!



Installation, Operating & Maintenance Instructions
Series 121, DN 200 - 250 (I.D. 8" - 10")

Imprint:

Manufacturer VAT Vakuumventile AG, CH-9469 Haag, Switzerland

Website
www.vatvalve.com

Phone
+41 81 771 61 61

Fax
+41 81 771 48 30

Email
CH@vatvalve.com

Publisher VAT Vakuumventile AG, CH-9469 Haag, Switzerland

Editor VAT Vakuumventile AG, CH-9469 Haag, Switzerland

Print VAT Vakuumventile AG, CH-9469 Haag, Switzerland

Copyright © VAT Vakuumventile AG 2008

No part of these Instructions may be reproduced in any way (photocopies, microfilms or any other reproduction processes) nor may it be manipulated with electronic systems, duplicated or distributed without written permission from VAT. Offenders are liable to pay damages.

The original VAT firmware and updated state of the art versions of the VAT firmware are intended for use with VAT products. The VAT firmware contains a limited, time unlimited user license. The VAT firmware may not be used for purposes other than those intended nor is it permitted to make copies of the VAT firmware. In particular, it is strictly forbidden to give copies of the VAT firmware to other people.

The use of trade names, brand names, trademarks, etc. in these Instructions does not entitle third parties to consider these names to be unprotected and to use them freely. This is in accordance with the meaning of the laws and acts covering brand names and trademarks.



Contents:

1	Use of product.....	4
1.1	Related documents	4
2	Installation.....	4
2.1	Unpacking	4
2.2	Installation into the system	5
2.2.1	Tightening torque for flange screws	5
2.2.2	Admissible forces	5
	Operation	6
2.3	Normal operation.....	6
2.4	Operation under increased temperature.....	6
3	Trouble shooting	7
4	Maintenance & repairs	7
4.1	Cleaning or replacement of gate seal and/or bonnet seal	8
4.2	Cleaning or replacement of locking balls	10
4.3	Cleaning or replacing of shaft feedthrough seals	11
5	Drawing	14
6	Spare parts	15
7	Warranty	16



1 Use of product

Use product for clean and dry indoor vacuum applications under the conditions indicated in chapter «Technical data» only! Other applications are only allowed with the written permission of VAT.

1.1 Related documents

- Product data sheet
- Dimensional drawing

2 Installation

2.1 Unpacking

Before unpacking the valve, make sure that the packaging is in impeccable condition and the valve has not suffered damage.

Note! The plastic packing material and/or protective covers may only be removed immediately before the valve is mounted into the system. Unprotected sealing surfaces must be treated with care and kept clean.

2.2 Installation into the system

The valve seat side is indicated by the symbol "∇" on the connection flange.

2.2.1 Tightening torque for flange screws

The screws of the flanges have to be tightened uniformly in crosswise order. The tightening torques indicated in the following table have to be observed.

DN		Tightening torque «Nm»			lbf · ft		
mm	inch	ISO	JIS	ASA-LP	ISO	JIS	ASA-LP
200	8	8 - 10	16 - 18	40 - 60	6 - 7.5	12 - 13	30 - 44
250	10	8 - 10	16 - 18	-	6 - 7.5	12 - 13	-

Higher tightening torques may deform the valve body. This can lead to improper function of the valve or to a leaky valve gate.

2.2.2 Admissible forces

Forces from evacuating the system and from the weight of other components can lead to deformation of the valve body and to malfunction of the valve. The stress has to be relieved by suitable means, e.g. bellows sections. The following forces are admissible:

DN (nom. I.D.)		Axial tensile or compressive force «FA»		Bending moment «M»		Maximum admissible torsional moment of body «TM»	
mm	inch	N	lbf	Nm	lbf · ft	Nm	lbf · ft
200	8	3000	674	150	110	12'000	8'850
250	10	3500	787	200	148	12'000	8'850

If a combination of forces («FA», «M» and «TM») occurs, the values mentioned above are invalid. Please contact VAT for more information.

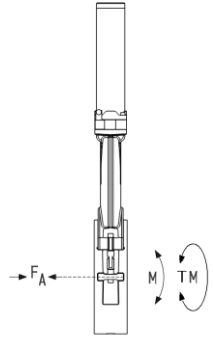



Operation

2.3 Normal operation

Valve is opened and closed manually.

2.4 Operation under increased temperature

See product data sheet.

The maximum temperatures indicated in the technical data are only valid as long as the valve is in one of the end positions. Cycling the valve at these temperatures may reduce the cycle life of the mechanism.

3 Trouble shooting

Failure	Check	Action
Leak at gate	Valve seat and gate seal clean?	Clean valve seat and gate seal, or replace gate seal
Leak at body	Flanges leaktight?	Tighten flange screws correctly
	Screws at upper part of body tightened?	Tighten bonnet screws correctly
		Replace bonnet seal

If you need any further information, please contact one of our service centers. You can find the addresses on our website: <http://www.vat.ch>

4 Maintenance & repairs

Under clean operating conditions, the valve does not require any maintenance during the specified cycle life. Contamination from the process may influence the function and requires more frequent maintenance.

Before carrying out any maintenance or repairs, please contact VAT. It has to be individually decided whether the maintenance/repair can be performed by the customer or has to be carried out by VAT. The fabrication number on the valve

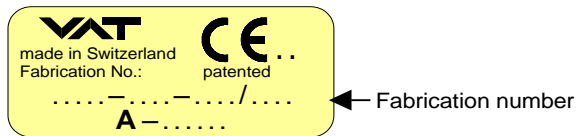

has always to be specified.

All supplies (e. g. compressed air, electrical power) must be disconnected for removal/installation of the valve from/into the system and for maintenance work.



Even with disconnected supply, loaded springs and/or air cushions in cylinders can be potential hazards.



Keep fingers and objects away from the valve opening!

Products returned to VAT must be free of harmful substances such as e.g. toxic, caustic or microbiological ones. If products are radioactively contaminated, fill in the VAT form «Contamination and Radiation Report» and send it with the product. The form is available at VAT. The maximum values indicated in the form must not be exceeded.

4.1 Cleaning or replacement of gate seal and/or bonnet seal

The figures in brackets refer to the drawing on page 14

The lower part of the body (flange part) need not be removed from the system for cleaning/replacing the gate seal and/or bonnet seal!

a) Separation of upper part of body (11) / actuator assembly from lower part of body (10):

1. Vent vacuum chambers on either side of valve
2. Open valve manually
3. Loosen and swing out both screws (12)
 - Attention:** Make sure to maintain upper part of body (11) / actuator assembly in its position while swinging out the screws!
4. Withdraw upper part of body (11) / actuator assembly carefully from lower part of body (10) and put it on a clean place (seat side symbol «∇» on top)

b) Cleaning or replacement of gate seal and bonnet seal:

5. Move mechanism manually out of upper part of body (11)
 - Attention:** Provide sufficient free space in order to prevent the mechanism from touching any objects!

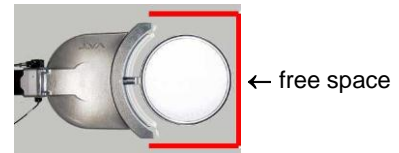

6. Clean (A) or replace (B) gate seal (1):

- (A)
 1. Leave gate seal in groove and clean it by using a lint-free cloth and alcohol
 2. Slightly lubricate seal with VAT vacuum grease [see «Spare parts»]
- (B)
 1. Pull gate seal out of groove by means of a scribing tool
 - Attention:** Be careful not to damage the bottom of the groove!
 2. Clean seal groove by using a lint-free cloth and alcohol
 3. Put new gate seal on seal groove and press it into groove uniformly and crosswise

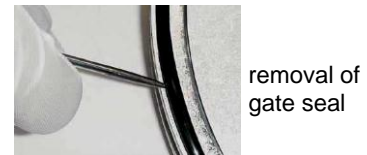

removal of gate seal



installation of gate seal

7. Clean (A) or replace (B) bonnet seal (2):
 - (A) 1. Leave bonnet seal in groove and clean it by using a lint-free cloth and alcohol
 2. Slightly lubricate seal with VAT vacuum grease [see «Spare parts»]
 - (B) 1. Pull bonnet seal out of groove by means of a scribing tool

Attention: Be careful not to damage the bottom of the groove!

 2. Clean seal groove by using a lint-free cloth and alcohol
 3. Put new bonnet seal on seal groove and press it into groove on one short side
 4. Distribute seal uniformly over long sides to opposite short side and press it fully into groove
8. Clean sealing surface of upper part of body (11) by using a lint-free cloth and alcohol
9. Clean sealing surface of valve seat on lower part of body (10) by using a lint-free cloth and alcohol

c) Mounting of upper part of body (11) / actuator assembly on lower part of body (10):

10. Make sure to have gate (16) on seat side «▽»:

Symbol «▽» on upper part of body (11)

Note: Mechanism with actuator shaft (13) is stiffly rotatable by 360°!

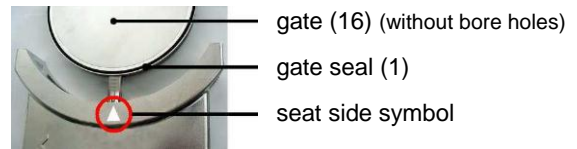

11. Align mechanism with opening of upper part of body (11)



correct



wrong

12. Move mechanism manually into upper part of body (11)

Attention:  Make sure to keep the space between body opening and mechanism free of any objects or body parts!
13. Set upper part of body (11) / actuator assembly carefully on lower part of body (10)

Attention: The tips of the triangles «▽» of both body parts must face each other!

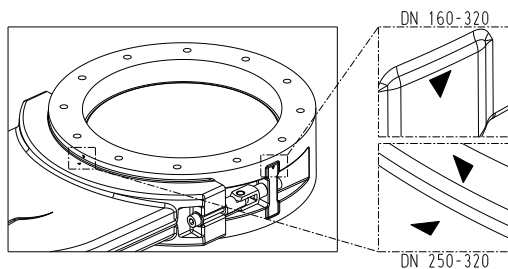

▽ on both body parts

14. Swing back both screws (12) and tighten them alternately

Tightening torque: DN 160 - 200: 14 Nm / 10.5 lbf · ft
 DN 250: 20 Nm / 15.0 lbf · ft
15. Perform function and leak test

4.2 Cleaning or replacement of locking balls

The figures in brackets refer to the drawing on page 14

The lower part of the body (flange part) need not be removed from the system for cleaning/replacing the locking balls! When the locking balls are cleaned/replaced, we recommend to clean the gate seal and bonnet seal as well (see relevant chapter).

a) Separation of upper part of body (11) / actuator assembly from lower part of body (10):

1. Carry out steps 1 - 6 of chapter «Cleaning or replacement of gate seal and/or bonnet seal», however with seat side «▽» down!

b) Cleaning or replacement of locking balls:

2. Move mechanism manually out of upper part of body (11)
Attention: Provide sufficient free space in order to prevent the mechanism from touching any objects!

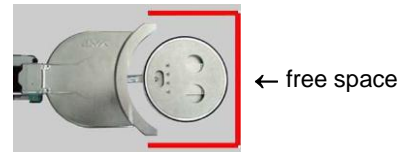

3. Remove lock nut (14) with disk (15)
4. Withdraw mechanism from actuator shaft (13) and put it on a clean place
5. Remove screws (19)
6. Lift off counter plate (17) carefully and put it on a clean place
7. Remove all visible balls (3) from ball guidance (18)
8. Lift off ball guidance (18) carefully and put it on a clean place
Attention: Balls can get caught in the lower ball sockets of the ball guidance (18)!
9. Remove all balls (3) from ball tracks in gate (16)
10. Clean (A) or replace (B) balls (3):
 - (A)
 1. Clean ball tracks in gate (16) and counter plate (17) by using a lint-free cloth, and check their condition with regard to wear
 2. Clean balls and ball sockets in ball guidance (18) by using a lint-free cloth and alcohol
 3. Lubricate balls with VAT vacuum grease [see «Spare parts»]
 4. Insert balls into ball tracks in gate (16)
 - (B)
 1. Clean ball tracks in gate (16) and counter plate (17) by using a lint-free cloth and alcohol, and check their condition with regard to wear
 2. Clean ball sockets in ball guidance (18) by using a lint-free cloth and alcohol
 3. Insert new, lubricated balls [see «Spare parts»] into ball tracks in gate (16)
 - (A + B)
 1. Put ball guidance (18) carefully on gate (16) so that balls (3) get into ball sockets
Attention: Regard correct position!



2. Insert remaining balls into ball sockets in ball guidance (18)

11. Put counter plate (17) on ball guidance

12. Insert and tighten screws (19)

Attention: The internal screws first, then the outside screws. **Tightening torque: DN200 5Nm / DN250 9Nm!**

13. Move mechanism on actuator shaft (13) to its stop

Attention: Spanner width of ball guidance (18) and shaft (13) must match!
Mechanism must not rotate against the shaft!

14. Mount lock nut (14) with disk (15)

15. Clean sealing surface of upper part of body (11) by using a lint-free cloth and alcohol

16. Clean sealing surface of valve seat on lower part of body (10) by using a lint-free cloth and alcohol

c) Mounting of upper part of body (11) / actuator assembly on lower part of body (10):

17. Carry out steps 13 - 20 of chapter «Cleaning or replacement of gate seal and/or bonnet seal»

Valve is ready for operation

4.3 Cleaning or replacing of shaft feedthrough seals

The figures in brackets refer to the drawing on page 14

The lower part of the body (flange part) need not be removed from the system for cleaning/replacing the shaft feedthrough seals! When the shaft feedthrough seals are cleaned/replaced, we recommend to clean the gate seal and bonnet seal as well (see relevant chapter).

a) Separation of upper part of body (11) / actuator assembly from lower part of body (10):

1. Carry out steps 1 - 6 of chapter «Cleaning or replacement of gate seal and/or bonnet seal», however with seat side «▽» down!

b) Cleaning or replacement of shaft feedthrough seals:

2. Move mechanism manually out of upper part of body (11)

Attention: Provide sufficient free space in order to prevent the mechanism from touching any objects!

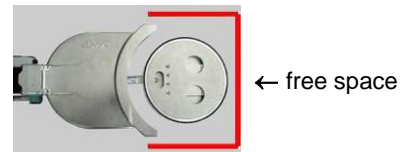

3. Remove lock nut (14) with disk (15)

4. Withdraw mechanism from actuator shaft (13) and put it on a clean place

5. Move actuator shaft (13) manually into upper part of body (11)

6. Put upper part of body (11) / actuator assembly in upright position (actuator on top)

7. Take a note in which position the actuator is mounted with regard to the seat side [see symbol «▽» on upper part of body (11)], so that the actuator can be mounted in the same position after completion of the maintenance work

8. Remove 4 screws (20)
9. Withdraw actuator from upper part of body (11) and put it on a clean place
10. Remove both seals (21) and spacer (22) carefully from upper part of body (11)
Attention: Be careful not to damage the sealing surface!
11. Clean feedthrough opening in upper part of body (11) and spacer (22) by using a lint-free cloth and alcohol
12. Clean (A) or replace (B) seals of shaft feedthrough (21); see drawing below
 - (A)
 1. Clean seals by using a lint-free cloth and alcohol
 2. Lubricate first seal extensively with VAT vacuum grease [see «Spare parts»] and insert it in feedthrough opening in upper part of body (11)
 3. Insert spacer (22)
 4. Lubricate second seal extensively with VAT vacuum grease [see «Spare parts»] and insert it in feedthrough opening in upper part of body (11)
 - (B)
 1. Lubricate first seal extensively with VAT vacuum grease [see «Spare parts»] and insert it in feedthrough opening in upper part of body (11)
 2. Insert spacer (22)
 3. Lubricate second seal extensively with VAT vacuum grease [see «Spare parts»] and insert it in feedthrough opening in upper part of body (11)
 - (A + B)
 1. Lubricate space between both seals extensively with VAT vacuum grease [see «Spare parts»]

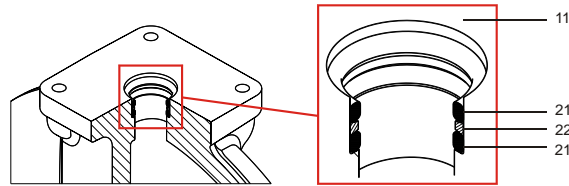

- 11 upper part of body
 21 first and second shaft feedthrough seal
 22 spacer = **space between both seals → area to be lubricated**

13. Clean actuator shaft (13):
 1. Move out actuator shaft manually in its full length
 2. Clean actuator shaft by using a lint-free cloth and alcohol
 3. Lubricate running surface of actuator shaft slightly with VAT vacuum grease [see «Spare parts»]
 4. Move back manually the actuator shaft
 5. Remove excessive grease from shaft
14. Put actuator on upper part of body (11)
Attention: Actuator must be mounted in the same position as it was before disassembly!
15. Mount and tighten 4 screws (20)
Tightening torque: DN 160: 6 Nm / 4.5 lbf · ft
DN 200 - 250: 14 Nm / 10.5 lbf · ft

16. Move actuator shaft manually out of upper part of body (11)
17. Remove excessive grease from shaft
18. Lubricate end piece of shaft without thread slightly with VAT vacuum grease [see «Spare parts»]

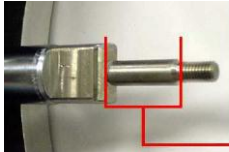

area to be lubricated

19. Move mechanism on actuator shaft (13) to its stop
Attention: Spanner width of ball guidance (18) and shaft (13) must match!
Mechanism must not rotate against the shaft!
20. Mount lock nut (14) with disk (15)
21. Clean sealing surface of upper part of body (11) by using a lint-free cloth and alcohol
22. Clean sealing surface of valve seat on lower part of body (10) by using a lint-free cloth and alcohol

c) Mounting of upper part of body (11) / actuator assembly on lower part of body (10):

23. Carry out steps 13 - 20 of chapter «Cleaning or replacement of gate seal and/or bonnet seal»

Valve is ready for operation

5 Drawing

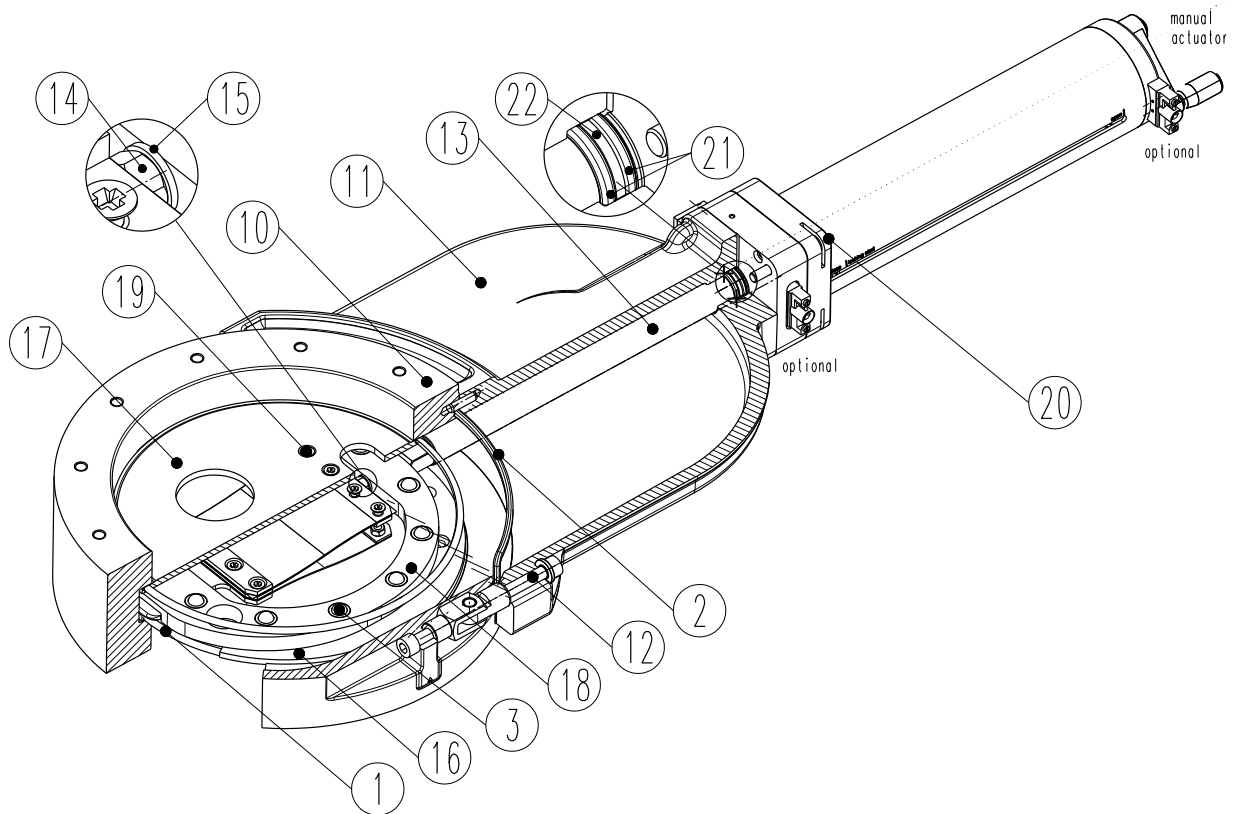

Sample picture

Item	Designation	Item	Designation	Item	Designation
1	gate seal	13	actuator shaft	19	countersunk-head screws
2	bonnet seal	14	lock nut	20	cylinder head screws
3	locking balls	15	disk	21	feedthrough seals
10	lower part of body	16	gate	22	spacer
11	upper part of body	17	counter plate		
12	swing screws	18	ball guidance		

6 Spare parts



Please specify the **fabrication number of the valve** (see yellow label on valve) when ordering spare parts. This is to ensure that the appropriate spare parts are supplied.

The item numbers refer to the drawing below

Item	Designation	Ordering No.	
		200	250
	DN		
	Seal kit ¹⁾	216859	216857
1	Gate seal	N-5100-266	N-5100-378
2	Bonnet seal	N-5100-264	N-5100-376
3	Spare parts kit «balls lubricated»	216864	216862
	VAT vacuum grease (10g)	N-6951-011	N-6951-011
4	Position indicators (optional)		

- ¹⁾ Seal kit includes:
 gate seal, bonnet seal, shaft feedthrough seals
 In most cases it is sufficient to replace the gate seal and bonnet seal only.

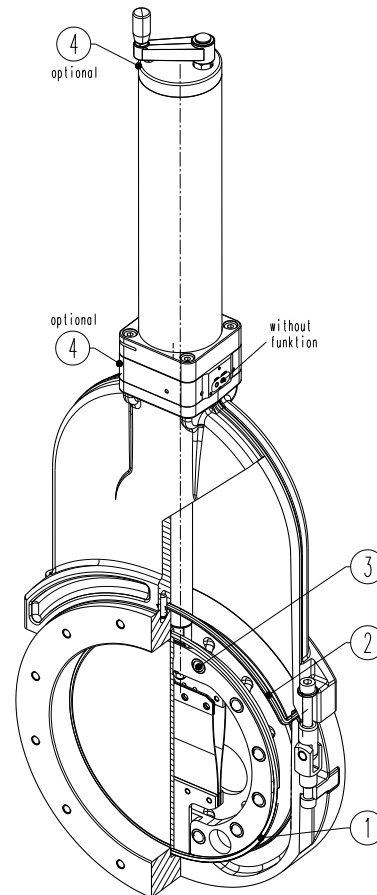

VAT Vakuumentile AG would be pleased to carry out the maintenance work for you. Please contact the VAT representative responsible for your country. You will find the addresses on our website www.vatvalve.com.

Please specify the **fabrication number** of the valve whenever you place an order for spare parts. The fabrication number is indicated on a yellow label attached to the actuator of the valve (see **product identification label** on page 1).

Attention: Use lubricated **VAT** spare parts only!

Sample picture



7 Warranty

Each product sold by VAT Vakuumventile AG (VAT) is warranted to be free from the manufacturing defects that adversely affect the normal functioning thereof during the warranty period stated in VAT's «Terms of Sale» immediately following delivery thereof by VAT, provided that the same is properly operated under conditions of normal use and that regular, periodic maintenance and service is performed or replacements made, in accordance with the instructions provided by VAT. The foregoing warranty shall not apply to any product or component that has been repaired or altered by anyone other than an authorized VAT representative or that has been subject to improper installation or abuse, misuse, negligence or accident. VAT shall not be liable for any damage, loss, or expense, whether consequential, special, incidental, direct or otherwise, caused by, arising out of or connected with the manufacture, delivery (including any delay in or failure to deliver), packaging, storage or use of any product sold or delivered by VAT shall fail to conform to the foregoing warranty or to the description thereof contained herein, the purchaser thereof, as its exclusive remedy, shall upon prompt notice to VAT of any such defect or failure and upon the return of the product, part or component in question to VAT at its factory, with transportation charges prepaid, and upon VAT's inspection confirming the existence of any defect inconsistent with said warranty or any such failure, be entitled to have such defect or failure cured at VAT's factory and at no charge therefor, by replacement or repair of said product, as VAT may elect. VAT MAKES NO WARRANTY OR REPRESENTATION OF ANY KIND, EXPRESS OR IMPLIED, (INCLUDING NO WARRANTY OR MERCHANTABILITY), EXCEPT FOR THE FOREGOING WARRANTY AND THE WARRANTY THAT EACH PRODUCT SHALL CONFORM TO THE DESCRIPTION THEREOF CONTAINED HEREIN, and no warranty shall be implied by law.

Furthermore, the «Terms of sale» at the back of the price list are applicable.