

## Butterfly Valve

Manually actuated

21036-PE06-.....

21040-PE06-.....

21044-PE06-.....

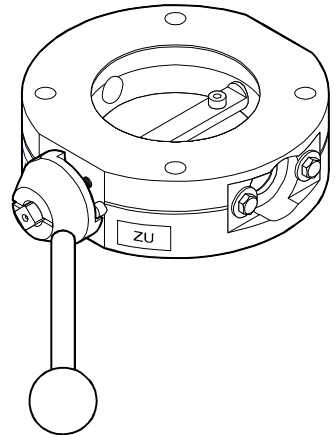

## Product Identification

In all communications with VAT, please specify the information on the product nameplate. For convenient reference copy that information into the space provided below.

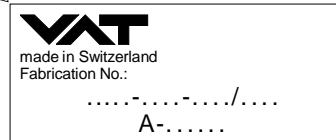
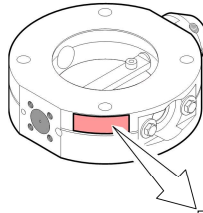

## Validity

This document applies to products with part numbers  
21036-PE06-....  
21040-PE06-....  
21044-PE06-....

The part number (No.) can be taken from the product nameplate.

If not indicated otherwise in the legends, the illustrations in this document correspond to the butterfly valve with the vacuum connection DN 63 ISO-F. They apply to butterfly valves with other vacuum connections by analogy.

We reserve the right to make technical changes without prior notice.

Dimensions in mm.

## Intended Use

Butterfly valves are manual valves for high vacuum applications.

## Functional Principle

The valve is opened and closed by turning the lever.

## Description

The valves have stainless steel housings with radially arranged flanges for the bypass line, gauge and/or venting valve. The valve drive can be installed on the opposite side of the valve, if it improves the accessibility of the lever.

## Contents

Product Identification	2
Validity	2
Intended Use	2
Functional Principle	2
Description	3
<b>1 Safety</b>	<b>5</b>
1.1 Symbols Used	5
1.2 Personnel Qualifications	5
1.3 General Safety Instructions	6
1.4 Liability and Warranty	6
<b>2 Technical Data</b>	<b>7</b>
<b>3 Installation</b>	<b>10</b>
3.1 Checking Accessibility of Lever	10
3.2 Making Vacuum Connection	11
3.3 Making Radially Arranged Vacuum Connections	12
<b>4 Operation</b>	<b>14</b>
<b>5 Deinstallation</b>	<b>15</b>
<b>6 Maintenance / Repair</b>	<b>19</b>
6.1 Disassembling the Valve	20
6.2 Cleaning the Valve	21
6.3 Reassembling the Valve	22
<b>7 Accessories</b>	<b>32</b>
<b>8 Spare Parts</b>	<b>33</b>
<b>9 Returning the Product</b>	<b>34</b>
<b>10 Disposal</b>	<b>35</b>

For cross-references within this document, the symbol  
 (→  XY) is used.

# 1 Safety

## 1.1 Symbols Used



Information on preventing any kind of physical injury.



Information on preventing extensive equipment and environmental damage.



Information on correct handling or use. Disregard can lead to malfunctions or minor equipment damage.

<...> Labeling

## 1.2 Personnel Qualifications



All work described in this document may only be carried out by persons who have suitable technical training and the necessary experience or who have been instructed by the end-user of the product.

### 1.3 General Safety Instructions

- Adhere to the applicable regulations and take the necessary precautions for the process media used. Consider possible reactions between the materials (→ 7) and the process media.
- Adhere to the applicable regulations and take the necessary precautions for all work you are going to do and consider the safety instructions in this document.
- Before beginning to work, find out whether any vacuum components are contaminated. Adhere to the relevant regulations and take the necessary precautions when handling contaminated parts.

Communicate the safety instructions to all other users.

### 1.4 Liability and Warranty

VAT assumes no liability and the warranty becomes null and void if the end-user or third parties

- disregard the information in this document
- use the product in a non-conforming manner
- make any kind of interventions (modifications, alterations etc.) on the product
- use the product with accessories not listed in the corresponding product documentation.

The end-user assumes the responsibility in conjunction with the process media used.

## 2 Technical Data

	21036-PE06- ....	21040-PE06- ....	21044-PE06- ....
Vacuum connection	DN 63 ISO-F	DN 100 ISO-F	DN 160 ISO-F
Radially arranged vacuum connections	DN 16 ISO-KF DN 10 ISO-KF	DN 25 ISO-KF 2x DN 10 ISO-KF	
Mounting orientation	any		
Number of cycles to first maintenance	100,000 <sup>1)</sup>		
Tightness	1x10 <sup>-9</sup> mbar l/s		
Conductance for air Molecular flow	350 l/s	1000 l/s	3400 l/s
Pressure range	10 <sup>-8</sup> mbar ... 4 bar		10 <sup>-8</sup> mbar ... 1.3 bar
Pressure difference in either direction	4 bar		1.3 bar
Ambiance temperature	5 ... 40 °C		
Bakeout temperature (housing)	150 °C		
Materials Housing, shaft, valve plate Seal	stainless steel 1.4301 FPM		
Weight	3.1 kg	5.2 kg	10.6 kg

<sup>1)</sup> Tested at  $\Delta p = 1$  mbar under clean conditions.

Dimensions [mm]

21036-PE06-000.

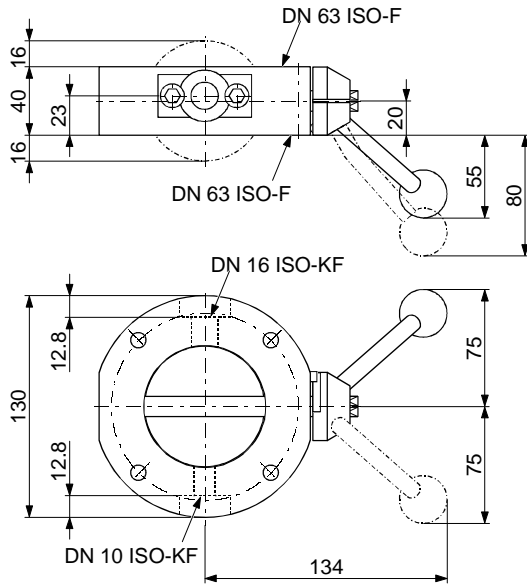



21040-PE06-....  
21044-PE06-....

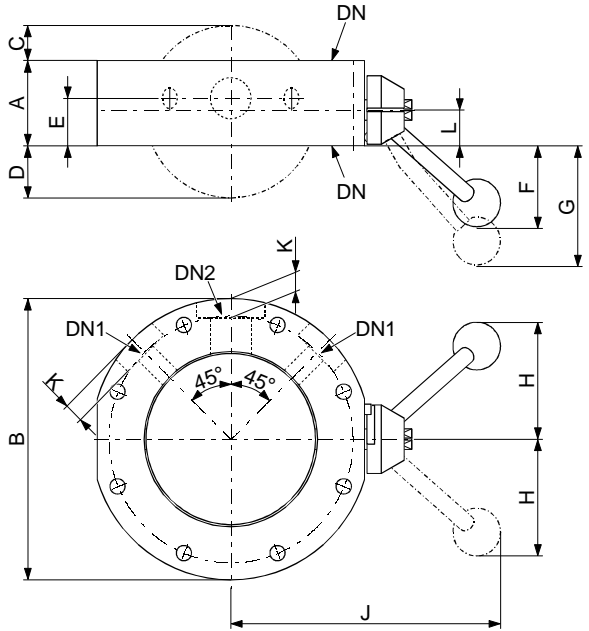

	DN	DN1	DN2
21040-PE06-....	DN 100 ISO-F	DN 10 ISO-KF	DN 25 ISO-KF
21044-PE06-....	DN 160 ISO-F	DN 10 ISO-KF	DN 25 ISO-KF

	A	B	C	D	E	F	G	H	J	K	L
21040-PE-06-....	50	165	22	30	28	55	80	75	150	11.3	21
21044-PE06-....	50	225	48.5	54.5	28	78	115	100	202	10.8	22

## 3 Installation



### Caution



Caution: vacuum component  
Dirt and damages impair the function of the vacuum component.

When handling vacuum components, take appropriate measures to ensure cleanliness and prevent damages.



### Caution



Caution: dirt sensitive area  
Touching the product or parts thereof with one's bare hands increases the desorption rate.

Always wear clean, lint-free gloves and use clean tools when working in this area.

### 3.1 Checking Accessibility of Lever

The valve drive can be installed on the opposite side of the valve if this improves the accessibility of the lever (→  20).

### 3.2 Making Vacuum Connection

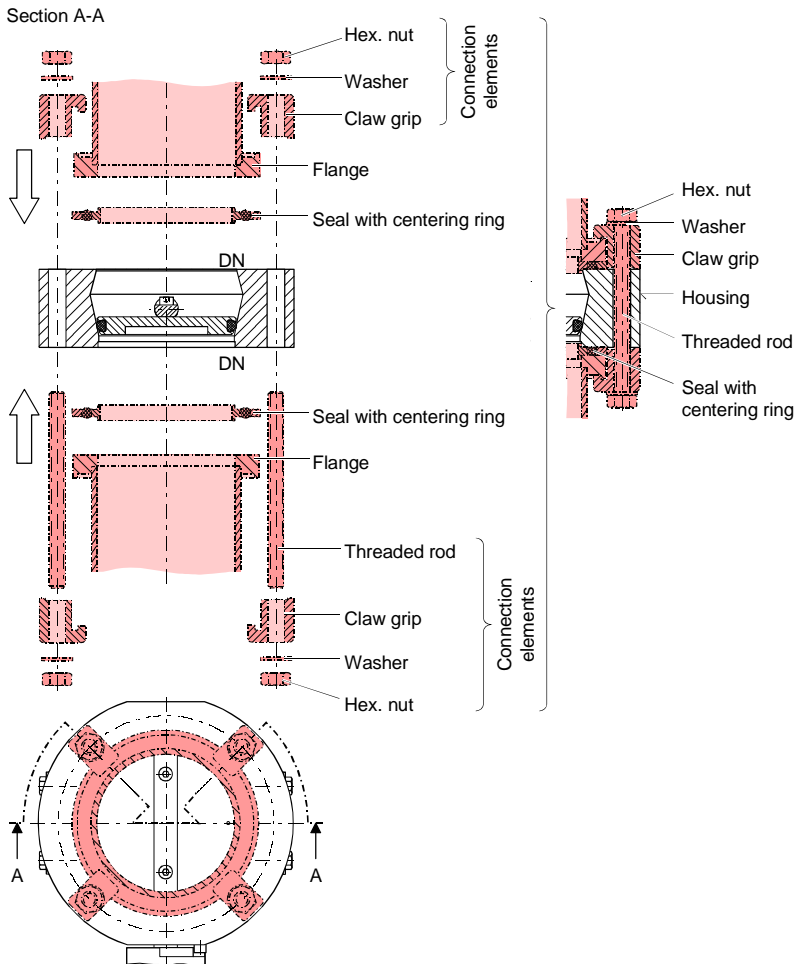

Connection elements → 32.

### 3.3 Making Radially Arranged Vacuum Connections

21036-PE06-....

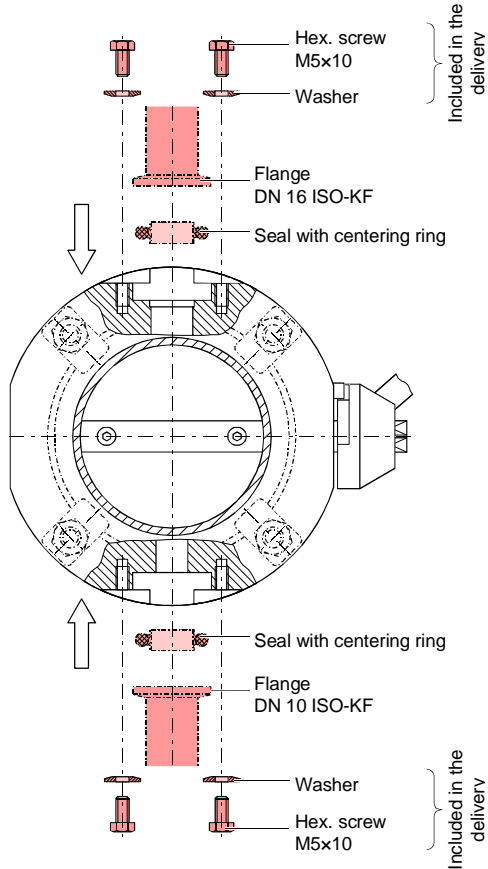

Cover the small flange connections that are not used with blanking flanges of the corresponding nominal diameter.

21040-PE06-....  
21044-PE06-....

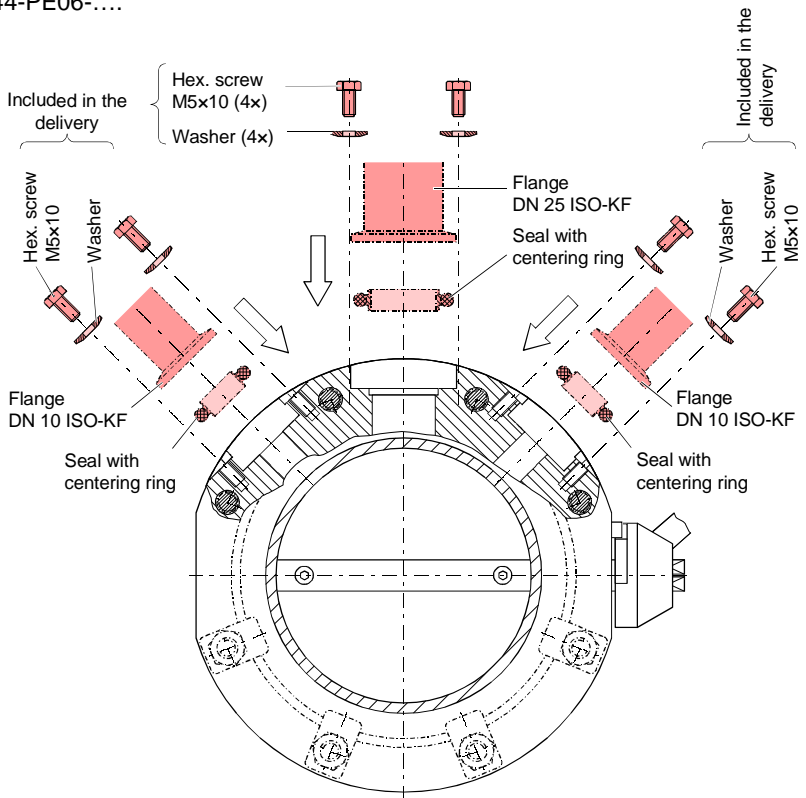

Cover the small flange connections that are not used with blanking flanges of the corresponding nominal diameter.

## 4 Operation

The product is ready for operation as soon as it has been installed.

Opening and closing the valve

Turning the lever by 90° from position <ZU> to position <AUF> opens and closes the valve.

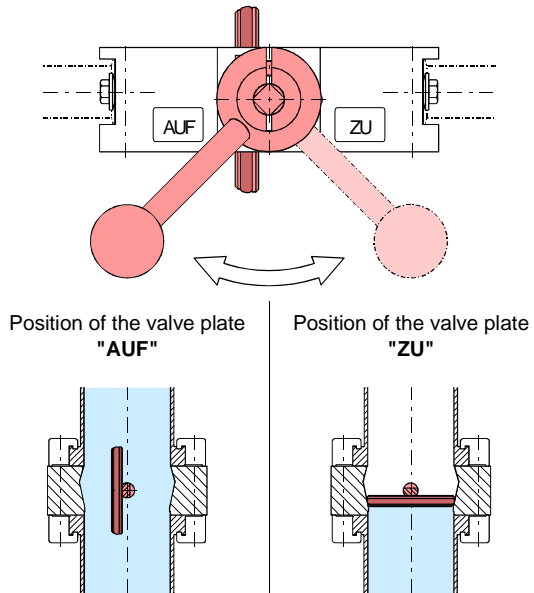

## 5 Deinstallation



### DANGER



Caution: contaminated parts

Contaminated parts can be detrimental to health and environment.

Before beginning to work, find out whether any parts are contaminated. Adhere to the relevant regulations and take the necessary precautions when handling contaminated parts.



### Caution



Caution: vacuum component

Dirt and damages impair the function of the vacuum component.

When handling vacuum components, take appropriate measures to ensure cleanliness and prevent damages.



### Caution



Caution: dirt sensitive area

Touching the product or parts thereof with one's bare hands increases the desorption rate.

Always wear clean, lint-free gloves and use clean tools when working in this area.

Precondition

Vacuum system vented.

Disconnecting the radially arranged vacuum connections

21036-PE06-....

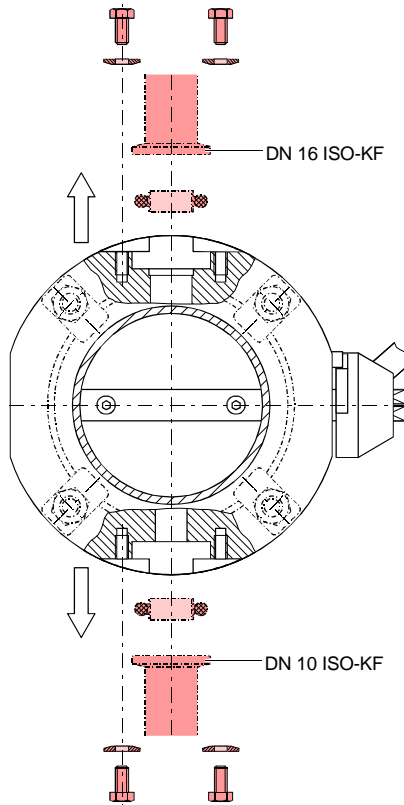



21040-PE06-....  
21044-PE06-....

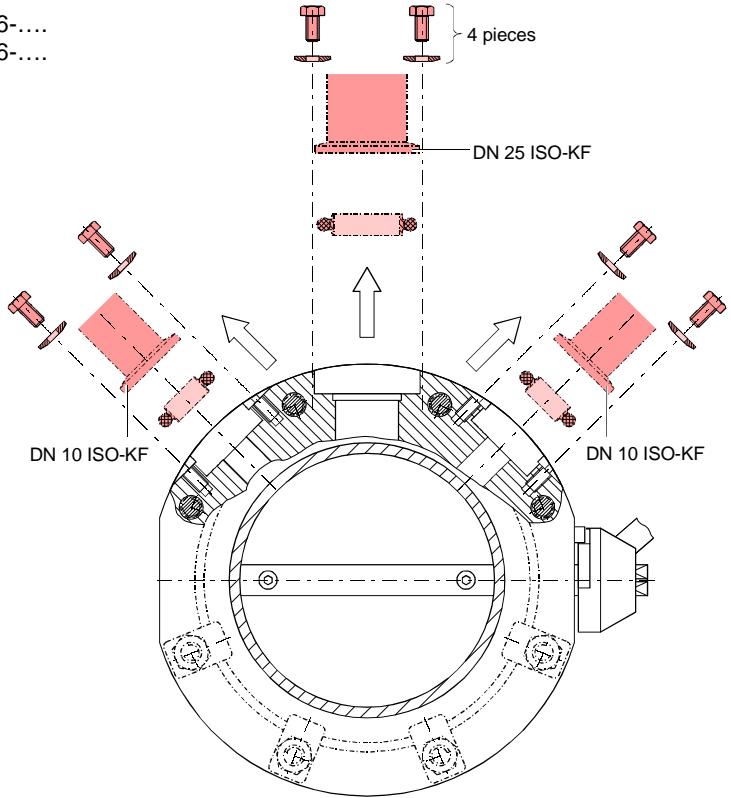

### Disconnecting the vacuum connection

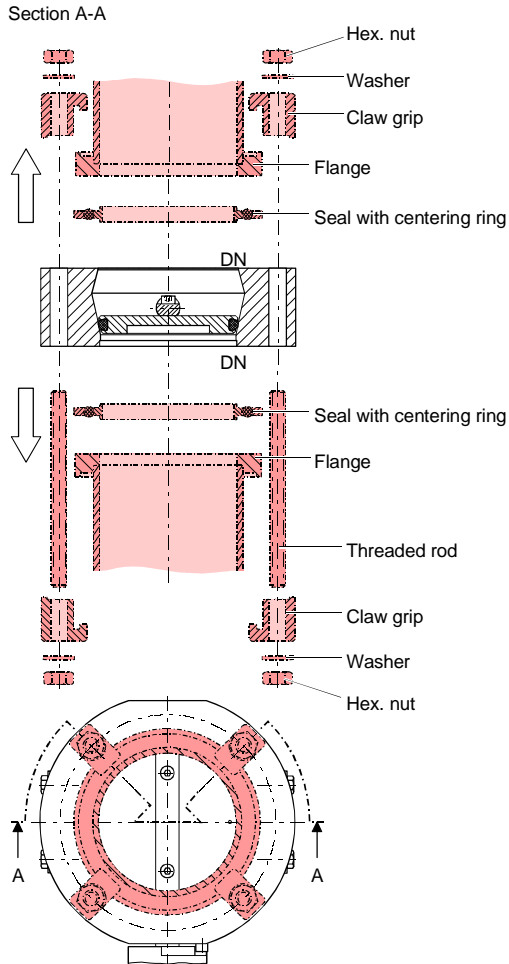

## 6 Maintenance / Repair



### DANGER



Caution: contaminated parts

Contaminated parts can be detrimental to health and environment.

Before beginning to work, find out whether any parts are contaminated. Adhere to the relevant regulations and take the necessary precautions when handling contaminated parts.



### Caution



Caution: vacuum component

Dirt and damages impair the function of the vacuum component.

When handling vacuum components, take appropriate measures to ensure cleanliness and prevent damages.

## 6.1 Disassembling the Valve

Precondition

Valve deinstalled (→ 15).

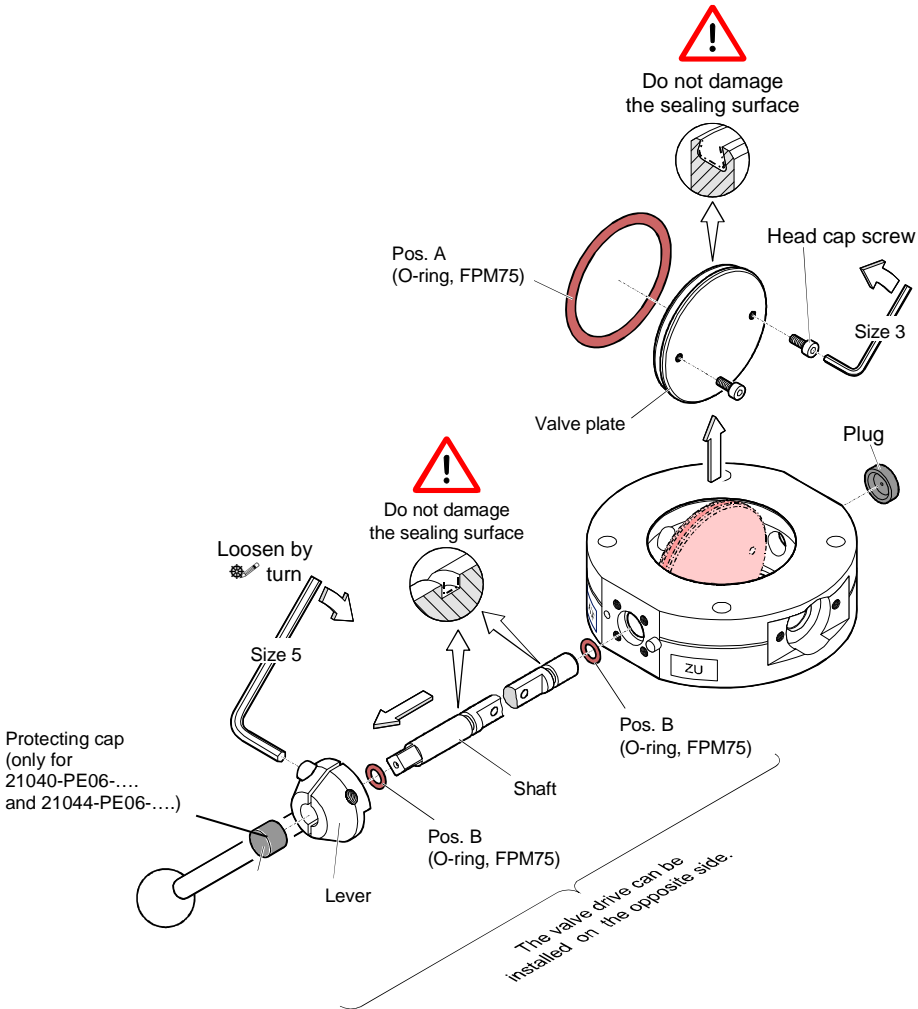

Pos.	Pieces	21036-PE06-....	21040-PE06-....	21044-PE06-....
A	1	ø59.69x5.34	ø91.44x5.34	ø139.06x5.34
B	2	ø7.59x2.62	ø7.59x2.62	ø10x3

Seal kit → 33.

## 6.2 Cleaning the Valve



**DANGER**

Caution: cleaning agents

Cleaning agents can be detrimental to health and environment.

Adhere to the relevant regulations and take the necessary precautions when handling and disposing of cleaning agents. Consider possible reactions with the product materials (→ 7).

### Procedure

- Carefully clean the parts with a grease solving, non-scouring cleaner.
- After cleaning, the parts should preferably be rinsed with alcohol and subsequently heated to  $\approx 50^{\circ}\text{C}$  in an oven or with an industrial blower.
- Carefully clean the sealing surfaces with a lint-free cloth soaked with alcohol. Allow them to dry.

### 6.3 Reassembling the Valve



#### Caution



Caution: dirt sensitive area

Touching the product or parts thereof with one's bare hands increases the desorption rate.

Always wear clean, lint-free gloves and use clean tools when working in this area.

#### Mounting the O-rings and installing the shaft

- 1 Lubricate the sealing groove with high vacuum lubricant FM 090 (Accessories → 32).

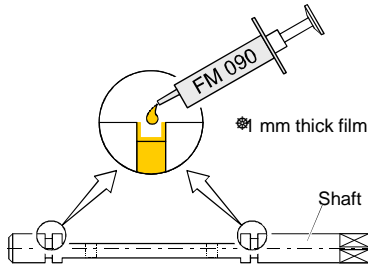

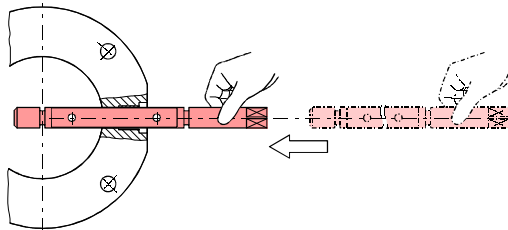

- 2 Carefully insert the shaft into the housing.



- 3** Slide one O-ring from the inside of the housing onto the shaft and insert O-ring level into the groove without twisting it.

Slide the second O-ring over the first.

 We recommend to use new O-rings (Spare parts →  33).

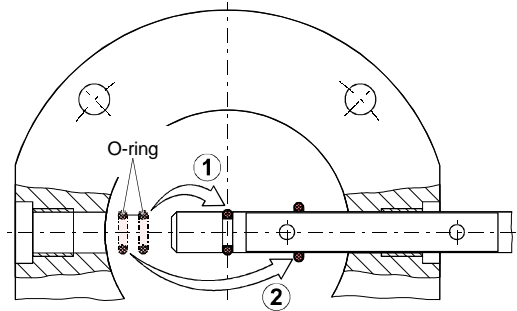

	Pieces	O-ring, FPM75
21036-PE06-....	2	ø7.59x2.62
21040-PE06-....	2	ø7.59x2.62
21044-PE06-....	2	ø10x3

- 4** Lubricate the visible surface of the O-ring, which has just been inserted into the groove, with high vacuum lubricant FM 090.

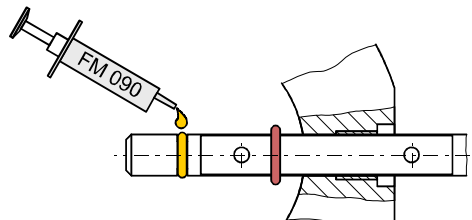

- 5** Push the shaft in further until the second groove is visible.

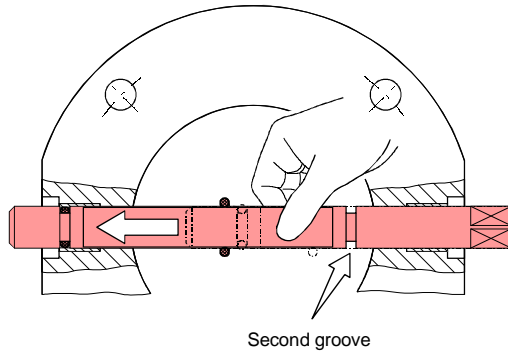

- 6** Insert the second O-ring level into the groove without twisting it.

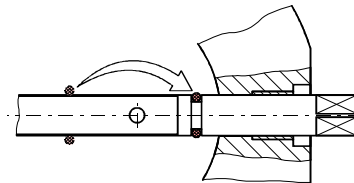



- 7** Lubricate the visible surface of the O-ring, which has just been inserted into the groove, with high vacuum lubricant FM 090.

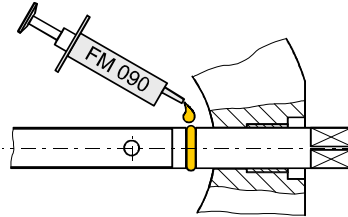

- 8** Slide the shaft to the axial position shown in the drawing and insert the plug.

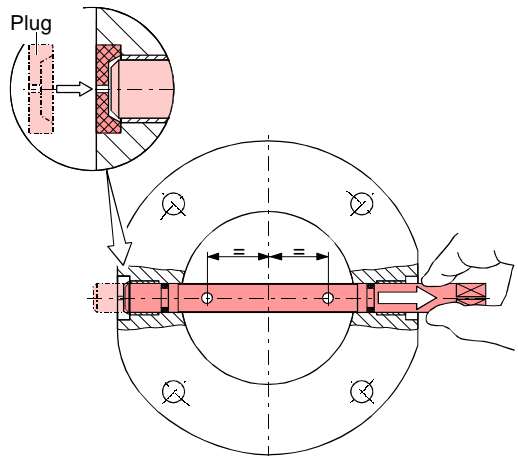

Mounting the O-ring onto the valve plate

- 9** Lubricate the sealing groove with high vacuum lubricant FU 090 (Accessories → 32) and insert the O-ring level into the groove without twisting it.

We recommend to use a new O-ring (Spare parts → 33).

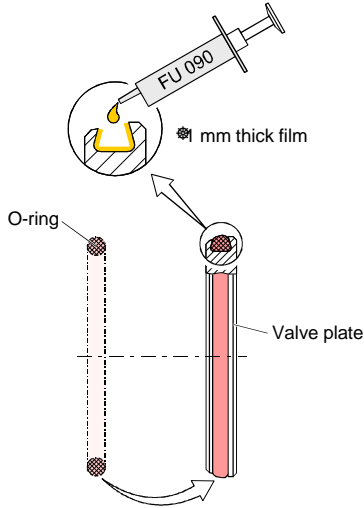

	O-ring, FPM75
21036-PE06-....	ø59.69x5.34
21040-PE06-....	ø91.44x5.34
21044-PE06-....	ø139.06x5.34

- 10** Lubricate the visible surface of the O-ring with high vacuum lubricant FU 090.

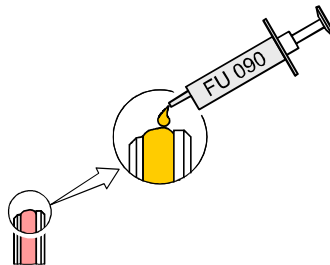

Pre-installing the valve plate

- 11 Carefully insert the valve plate into the housing on the opposite side of the countersinking and manually screw in the head cap screw.

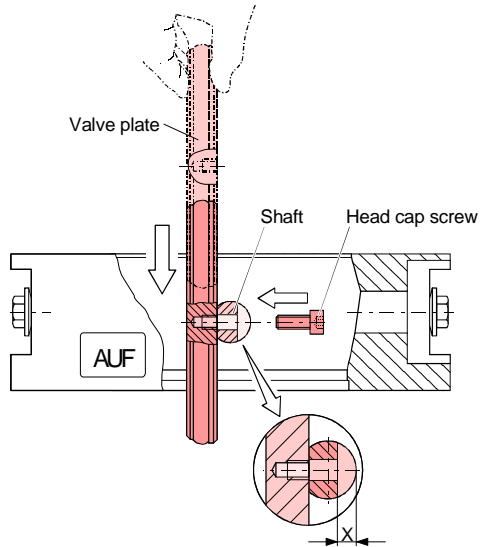

	Pieces	Head cap screw
21036-PE06-...	2	M4x10
21040-PE06-....	3	M4x10
21044-PE06-....	4	M4x12

- 12 Tilt the valve plate by  $\approx 45^\circ$  and screw the shaft in slightly.

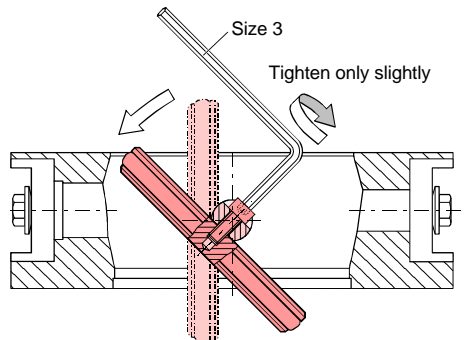

Centering and tightening the valve plate

- 13** Bring the valve plate to the <ZU> position by turning the square neck counter-clockwise, e.g. using a wrench.

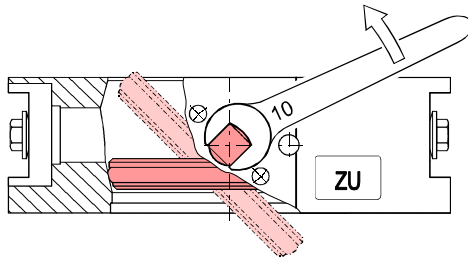

- 14** Loosen the head cap screws by  $\approx 1$  turn to allow the valve plate to center itself.

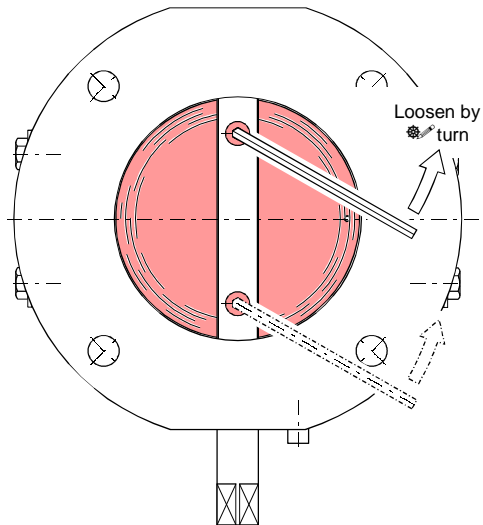

- 15 Tighten the head cap screws to a torque of 3 Nm.

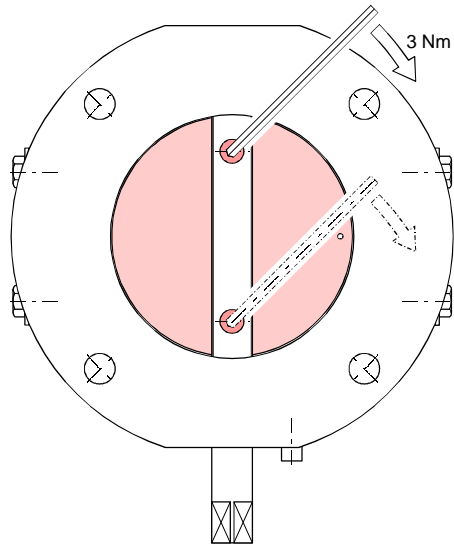

Mounting the lever

**16** Slide the lever onto the shaft ...

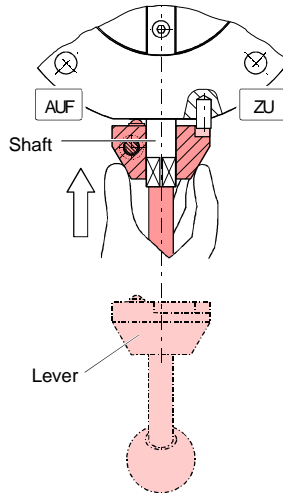

... and turn it counter-clockwise up to the stop position (pin).

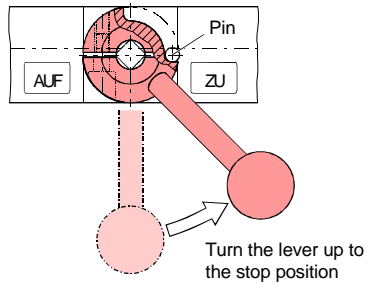

- While the lever is in the position described at step 16 press it against the housing ...

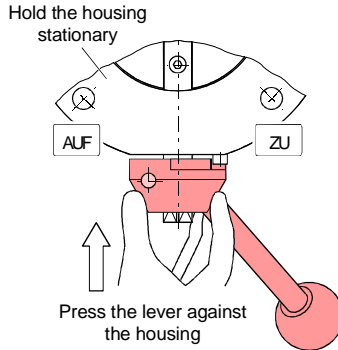

... and tighten the head cap screw to a torque of 9 Nm.

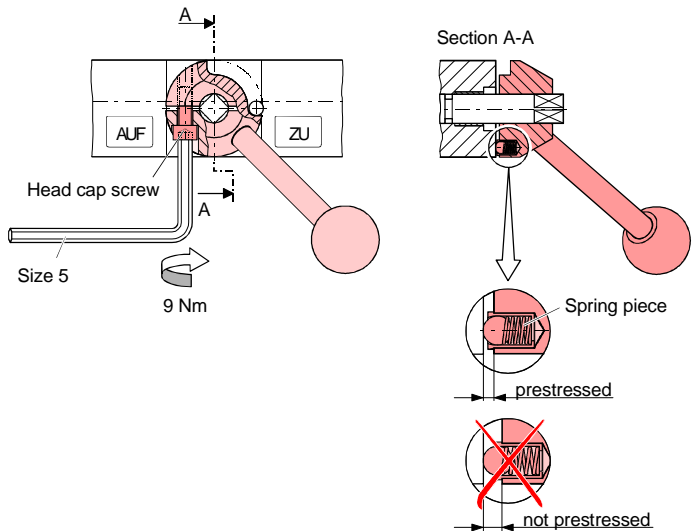

- In this position, the spring piece for positioning the lever is prestressed.

## 7 Accessories

		Ordering number
Set of connection elements (21036-PE06-....) comprising		580672
4 threaded rods M8x100		
8 claw grips		
8 washers		
8 hex. nuts	M8	
Set of connection elements (21040-PE06-....) comprising		580691
8 threaded rods	M8x110	
16 claw grips		
16 washers		
16 hex. nuts	M8	
Set of connection elements (21044-PE06-....) comprising		580706
8 threaded rods	M10x115	
16 claw grips		
16 washers		
16 hex. nuts	M10	
		Ordering number
High vacuum lubricant	FM 090, 30 g FU 090, 10 g	583409 N-6951-011



## 8 Spare Parts

	Ordering number
Seal kit (21036-PE06-....) comprising 1 O-ring, FPM75 $\varnothing 59.69 \times 5.34$ 2 O-rings, FPM75 $\varnothing 7.59 \times 2.62$	579965
Seal kit (21040-PE06-....) comprising 1 O-ring, FPM75 $\varnothing 91.44 \times 5.34$ 2 O-rings, FPM75 $\varnothing 7.59 \times 2.62$	580187
Seal kit (21044-PE06-....) comprising 1 O-ring, FPM75 $\varnothing 139.06 \times 5.34$ 2 O-rings, FPM75 $\varnothing 10 \times 3$	580255

## 9 Returning the Product



**WARNING**



Caution: forwarding contaminated products  
Contaminated products (e.g. radioactive, toxic, caustic or microbiological hazard) can be detrimental to health and environment.

Products returned to VAT should preferably be free of harmful substances. Adhere to the forwarding regulations of all involved countries and forwarding companies and enclose a duly completed declaration of contamination The form can be downloaded from our website [www.vatvalve.com](http://www.vatvalve.com).

Products that are not clearly declared as "free of harmful substances" are decontaminated at the expense of the customer.

Products not accompanied by a duly completed declaration of contamination are returned to the sender at his own expense.

## 10 Disposal



### DANGER

Caution: contaminated parts

Contaminated parts can be detrimental to health and environment.

Before beginning to work, find out whether any parts are contaminated. Adhere to the relevant regulations and take the necessary precautions when handling contaminated parts.



### WARNING



Caution: substances detrimental to the environment

Products or parts thereof (mechanical and electric components, operating fluids etc.) can be detrimental to the environment.

Dispose of such substances in accordance with the relevant local regulations.

Separating the components

Contaminated components

Other components

After disassembling the product, separate its components according to the following criteria:

Contaminated components (radioactive, toxic, caustic, or biological hazard etc.) must be decontaminated in accordance with the relevant national regulations, separated according to their materials, and disposed of.

Such components must be separated according to their materials and recycled.

