

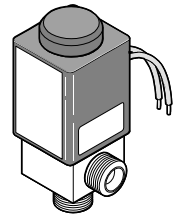

Vacuum angle valve

electromagnetically operated
21414-XE64-000.



Operating Manual

601454EA (2013-05)

Product Identification

In all communications with VAT, please specify the information on the product nameplate. For convenient reference copy that information into the space provided below.

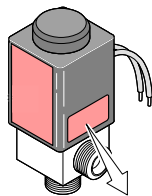

Validity

This document applies to products with part number 21414-XE64-000..

The part number (PN) can be taken from the product nameplate.

We reserve the right to make technical changes without prior notice.

All dimensions in mm.

Intended Use

The mini angle valve is predominantly used in fast-cycling vacuum systems, e.g. for gas analysis and coating processes.

Functional Principle

The valve is opened by the solenoid coil and closed by the prestressed pressure spring. It closes, or remains closed, on power loss.

Safety

Symbols Used

STOP DANGER
Information on preventing any kind of physical injury.

WARNING
Information on preventing extensive equipment and environmental damage.

Caution
Information on correct handling or use. Disregard can lead to malfunctions or minor equipment damage.

Personnel Qualifications

Skilled personnel
All work described in this document may only be carried out by persons who have suitable technical training and the necessary experience or who have been instructed by the end-user of the product.

General Safety Instructions

- Adhere to the applicable regulations and take the necessary precautions for the process media used. Consider possible reactions between the materials (→ "Technical Data") and the process media. Consider possible reactions of the process media due to the heat generated by the product.
- Adhere to the applicable regulations and take the necessary precautions for all work you are going to do and consider the safety instructions in this document.
- Before beginning to work, find out whether any vacuum components are contaminated. Adhere to the relevant regulations and take the necessary precautions when handling contaminated parts.

Communicate the safety instructions to all other users.

Liability and Warranty

VAT assumes no liability and the warranty becomes null and void if the end-user or third parties

- disregard the information in this document
- use the product in a non-conforming manner
- make any kind of interventions (modifications, alterations etc.) on the product
- use the product with accessories not listed in the corresponding product documentation.

The end-user assumes the responsibility in conjunction with the process media used.

Failures due to contamination or wear and tear, as well as expendable parts (e.g. seals), are not covered by the warranty.

Technical Data

Version	normally closed
Nominal diameter	ø5 mm / M14x1
Vacuum connections (accessories)	<ul style="list-style-type: none"> flange fitting DN 10 ISO-KF pipe connection OD 1/4" pipe connection OD 6 mm
Power specifications	
Nominal voltage	24 VDC ±10%
Nominal power	10 W
Duty cycle	100% (i.e. continuous duty possible)
Degree of protection	IP 65
Conductance for air	
Molecular flow	0.3 l/s
Laminar flow	3 l/s
Mounting orientation	any
Switching frequency max.	300 / min ¹⁾
Cycles to first maintenance	≈2 million ²⁾
Tightness	1x10 ⁻⁹ mbar l/s
Resistance to pressure	10 bar (absolute)
Operating pressure	1x10 ⁻⁹ mbar ... 1 bar
Pressure difference Δp	
In closing direction	5 bar
In opening direction	1.5 bar
Opens against a pressure difference Δp	1 bar (with 24 VDC)
Closing time	7 ms ¹⁾
Opening time	30 ms ¹⁾
Temperature	
Ambiance	5 °C ³⁾ ... 40 °C
Heat generation	60 °C (after 1 1/4 hours on continuous duty)
Bakeout	120 °C (with idle solenoid coil) 150 °C (without solenoid coil)
Materials	
Housing	stainless steel 1.4301
Actuator	stainless steel 1.4105
Seals	FPM
Weight	0.3 kg

- ¹⁾ With pressure difference Δp = 0 bar.
²⁾ Under clean operating conditions. If the valve is operated under harsh or dirty conditions, it should be cleaned / maintained before the specified service time to maintenance has been reached.
³⁾ -15 °C, if the ambience is free of condensable gases.

Dimensions [mm]

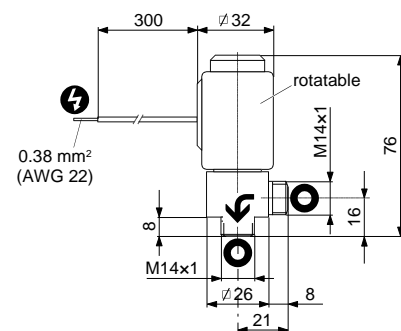

- Power connection
- Protective lid
- Flow direction

Installation dimensions with accessories [mm] (ordering numbers → "Installation")

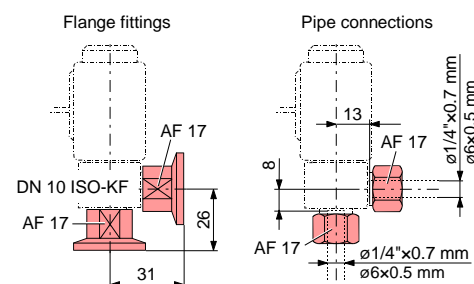

Flange fitting and pipe connections

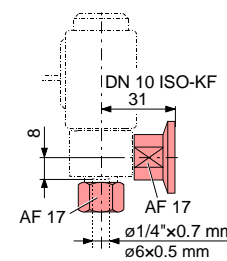

Installation

Vacuum Connection

Caution
Dirt and damages impair the function of the vacuum component. When handling vacuum components, take appropriate measures to ensure cleanliness and prevent damages.

Caution
Touching the product or parts thereof with bare hands increases the desorption rate. Always wear clean, lint-free gloves and use clean tools when working in this area.

Accessories (1 piece per part number).

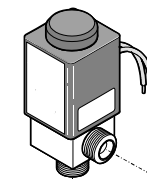

- Flange fitting DN 10 ISO-KF
Part no. 579211
- Pipe connection OD 1/4"
Part no. 579257
- Pipe connection OD 6 mm
Part no. 579257
- Pipe connection OD 6 mm
Part no. 579292

Flange connections

- Remove the protective lids and mount two flange fittings.

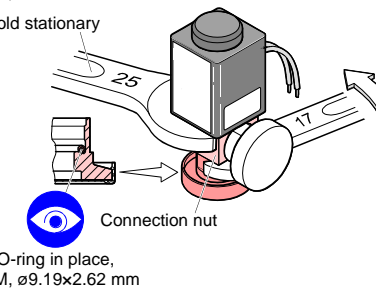
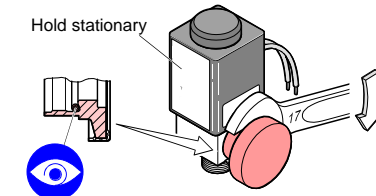

- Remove the protective lids and install the product to the vacuum system.

DANGER
DANGER: overpressure in the vacuum system >1 bar
Injury caused by released parts and harm caused by escaping process gases can result if clamps are opened while the vacuum system is pressurized. Do not open any clamps while the vacuum system is pressurized. Use the type of clamps which are suited to overpressure.

DANGER
DANGER: overpressure in the vacuum system >2.5 bar
KF flange connections with elastomer seals (e.g. O-rings) cannot withstand such pressures. Process media can thus leak and possibly damage your health. Use O-rings provided with an outer centering ring.

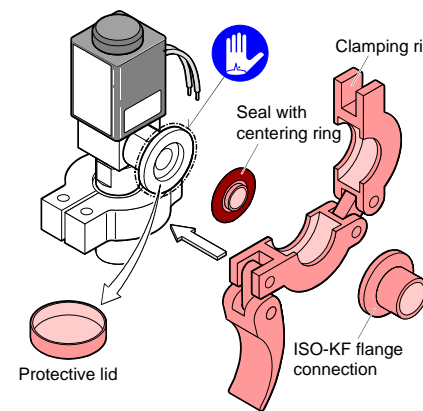

- Keep the protective lids.

- Check that the vacuum connections are leak tight.

Tube connections

- Cut the tube to the required length and remove the burs.
- Slide the union nut and clamping rings over the tube.
- Remove the protective lid and insert the tube until the mechanical stop is reached.

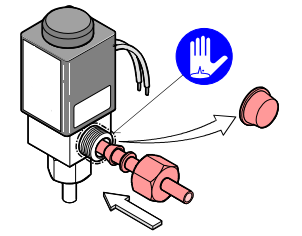
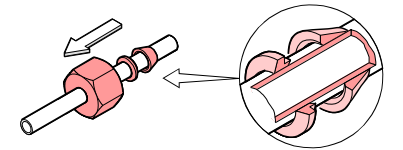

- Keep the protective lids.

- Slide the clamping rings up to the mechanical stop.

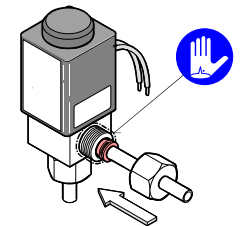

- Tighten the union nut with your fingers.

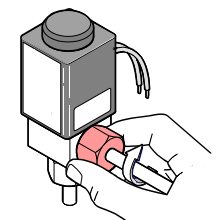

- Tighten the union nut
 - initial installation by 3/4 turns (stainless steel)
 - subsequent installation by 1/4 turns (stainless steel).

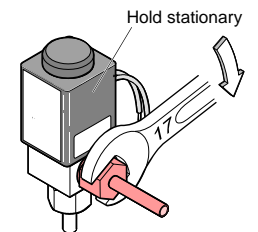

- Check that the vacuum connections are leak tight.

Power Connection

Bring the cable strands into the desired position

- 1 Remove the protective cap, unfasten the hexagon nut and rotate the solenoid coil until the cable strands are in the desired position.

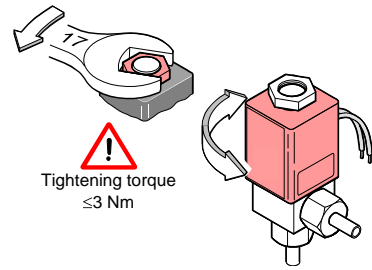

- 2 Tighten the hexagon nut with a torque of ≤3 Nm and place the protective cap.

Establish the electrical connection

Der elektrische Anschluss erfolgt über die zwei offenen Kabelenden. Dabei sind die örtlichen Installationsvorschriften zu beachten.

Caution

- Caution: switching of inductive loads (solenoid coil)
- Inductive loads may considerably reduce the service life of or even destroy contacts.
- Preferably a clamping diode should be connected in parallel to the solenoid coil. The polarity should be chosen in such a way that the diode blocks when normal operating voltage is available.

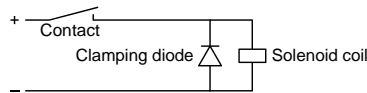

- Before connecting or disconnecting the product, turn off the control system.

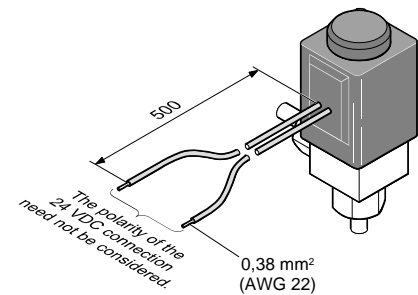

Operation

The product is ready for operation as soon as it has been installed.

Version: Normally closed.

DANGER

- DANGER: hot surface
- Touching the hot surface (>55 °C) can cause burns.
- Wear protective gloves.

Deinstallation

DANGER

- DANGER: contaminated parts
- Contaminated parts can be detrimental to health and environment.
- Before beginning to work, find out whether any parts are contaminated. Adhere to the relevant regulations and take the necessary precautions when handling contaminated parts.

Caution

- Caution: vacuum component
- Dirt and damages impair the function of the vacuum component.
- When handling vacuum components, take appropriate measures to ensure cleanliness and prevent damages.

Caution

- Caution: dirt sensitive area
- Touching the product or parts thereof with bare hands increases the desorption rate.
- Always wear clean, lint-free gloves and use clean tools when working in this area.

Preconditions:

- Vacuum system vented
- Valve cooled down to <55 °C

- 1 Disconnect the product from the power source.

- Before connecting or disconnecting the product, turn off the control system.

- 2 Remove the valve from the vacuum system and install the protective lids.

Flange connections

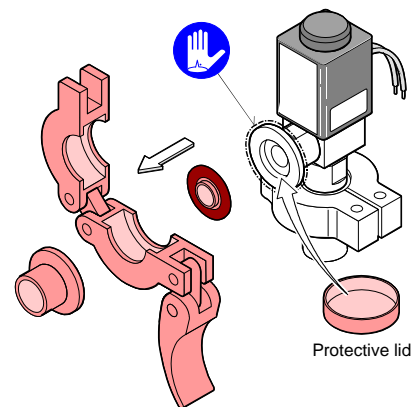

Pipe connections

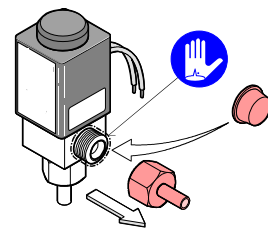

Maintenance, Repair

Under clean operating conditions the product requires no maintenance during the rated cycle life.

- Failures due to contamination or wear and tear, as well as expendable parts (e.g. seals), are not covered by the warranty.

DANGER

- DANGER: contaminated parts
- Contaminated parts can be detrimental to health and environment.
- Before beginning to work, find out whether any parts are contaminated. Adhere to the relevant regulations and take the necessary precautions when handling contaminated parts.

Caution

- Caution: vacuum component
- Dirt and damages impair the function of the vacuum component.
- When handling vacuum components, take appropriate measures to ensure cleanliness and prevent damages.

Caution

- Caution: dirt sensitive area
- Touching the product or parts thereof with bare hands increases the desorption rate.
- Always wear clean, lint-free gloves and use clean tools when working in this area.

Precondition: Valve deinstalled.

- 1 Unfasten and remove the hexagon nut.

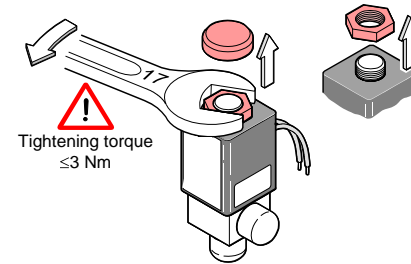

- 2 Remove the solenoid coil.

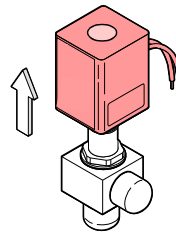

- 3 Unscrew the guiding tube and disassemble it.

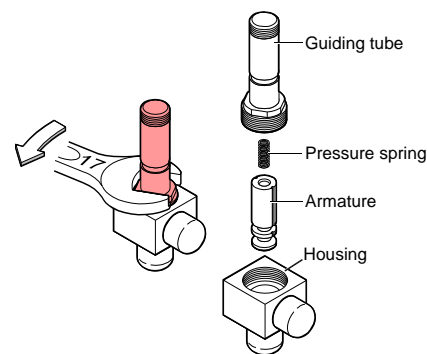

- 4 Remove the O-rings.

- When reassembling the product: be careful to insert the O-rings level into the grooves without twisting them.

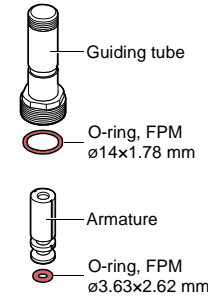

- 5 Clean the valve and replace its parts (→ "Spare Parts").

DANGER

- DANGER: cleaning agents
- Cleaning agents can be detrimental to health and environment.
- Adhere to the relevant regulations and take the necessary precautions when handling cleaning agents and disposing of them. Consider possible reactions with the product materials.

- Carefully clean the parts with a grease solving, non-scouring cleaner.
- After cleaning, the parts should preferably be rinsed with alcohol and subsequently heated to ~50 °C in an oven or with an industrial blower.
- Carefully clean the sealing surfaces with a lint-free cloth moistened with alcohol. Allow them to dry.
- Wipe the seals with a lint-free cloth slightly moistened with vacuum oil.

- 6 Proceed in reverse order to reassemble the valve.

- After reassembly, a few switching cycles should be performed in order for the O-rings to perfectly adapt to the sealing surfaces.

Spare Parts

When ordering spare parts, always indicate:

- All information on the product nameplate
- Description and ordering number according to the spare parts list

	Ordering no.
Seal kit, comprising 5x O-ring, FPM 75, ø1.78x1.78 ¹⁾ 5x O-ring, FPM 75, ø7.66x1.78 ¹⁾ 5x O-ring, FPM 75, ø3.63x2.62 5x O-ring, FPM 75, ø14x1.78	586395
Spare parts kit, comprising 1x solenoid coil 24 VDC / 10 W ¹⁾ 1x pressure spring, stainless steel 1x protective cap, AF 17 1x O-ring, FPM 75, ø14x1.78 mm 1x O-ring, FPM 75, ø3.63x2.62 mm	586391

- ¹⁾ Not required for his valve
- ¹⁾ The included hexagonal nut is not needed

Storage

Caution

- Caution: vacuum component
- Inappropriate storage leads to an increase of the desorption rate and/or may result in mechanical damage of the product.
- Cover the vacuum ports of the product with protective lids or grease free aluminum foil. Do not exceed the admissible storage temperature range (→ "Technical Data").

Returning the Product

WARNING

- WARNING: forwarding contaminated products
- Contaminated products (e.g. radioactive, toxic, caustic or biological hazard) can be detrimental to health and environment.
- Products returned to VAT should preferably be free of harmful substances. Adhere to the forwarding regulations of all involved countries and forwarding companies and enclose a duly completed declaration of contamination. The form can be downloaded from our website www.vatvalve.com.

Products that are not clearly declared as "free of harmful substances" are decontaminated at the expense of the customer.

Products not accompanied by a duly completed declaration of contamination are returned to the sender at his own expense.

Disposal

DANGER

- DANGER: contaminated parts
- Contaminated parts can be detrimental to health and environment.
- Before beginning to work, find out whether any parts are contaminated. Adhere to the relevant regulations and take the necessary precautions when handling contaminated parts.

WARNING

- WARNING: substances detrimental to the environment
- Products or parts thereof (mechanical and electric components, operating fluids etc.) can be detrimental to the environment.
- Dispose of such substances in accordance with the relevant local regulations.

Separating the components

After disassembling the product, separate its components according to the following criteria:

- Contaminated components
- Contaminated components (radioactive, toxic, caustic, or biological hazard etc.) must be decontaminated in accordance with the relevant national regulations, separated according to their materials, and disposed of.
- Other components
- Such components must be separated according to their materials and recycled.