

HV-Angle Valve (Series 264)
HV-Inline Valve (Series 265)
 with electromagnetic actuator
 single acting with closing spring (NC)

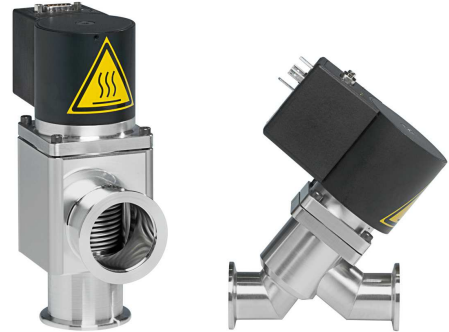

This manual is valid for the valve ordering number(s):
 26...

26428-KA61

→ A ..	Aluminum	→ E ..	Stainless Steel
→ K ..	ISO-KF	→ G ..	CF-R
→ 28..	DN 25	→ 32 ..	DN 40
→ 4 ..	Angle Valve	→ 5 ..	Inline Valve

The Serial / Fabrication number is indicated on each product as per the label below (or similar):

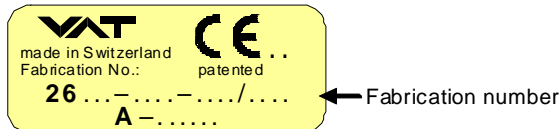

Explanation of symbols:



Read declaration carefully before you start any other action!



Keep body parts and objects away from the valve opening!



Attention!



Hot surfaces; do not touch!



Product is in conformity with EC guidelines, if applicable!



Loaded springs and/or air cushions are potential hazards!



Disconnect electrical power and compressed air lines. Do not touch parts under voltage!



Wear gloves!



Installation, Operating & Maintenance Instructions
Series 264, DN 25 - 40 (I.D. 1 - 1 1/2")



Read these «**Installation, Operating & Maintenance Instructions**» and the enclosed «**General Safety Instructions**» carefully before you start any other action!



Installation, Operating & Maintenance Instructions
Series 264, DN 25 - 40 (I.D. 1 - 1 1/2")

Imprint:

Manufacturer VAT Vakuumventile AG, CH-9469 Haag, Switzerland

Website	Phone	Fax	Email
www.vatvalve.com	+41 81 771 61 61	+41 81 771 48 30	CH@vatvalve.com

Publisher VAT Vakuumventile AG, CH-9469 Haag, Switzerland

Editor VAT Vakuumventile AG, CH-9469 Haag, Switzerland

Print VAT Vakuumventile AG, CH-9469 Haag, Switzerland

Copyright © VAT Vakuumventile AG 2008

No part of these Instructions may be reproduced in any way (photocopies, microfilms or any other reproduction processes) nor may it be manipulated with electronic systems, duplicated or distributed without written permission from VAT. Offenders are liable to pay damages.

The original VAT firmware and updated state of the art versions of the VAT firmware are intended for use with VAT products. The VAT firmware contains a limited, time unlimited user license. The VAT firmware may not be used for purposes other than those intended nor is it permitted to make copies of the VAT firmware. In particular, it is strictly forbidden to give copies of the VAT firmware to other people.

The use of trade names, brand names, trademarks, etc. in these Instructions does not entitle third parties to consider these names to be unprotected and to use them freely. This is in accordance with the meaning of the laws and acts covering brand names and trademarks.



Contents:

1	Use of product	5
2	Technical data.....	5
3	Installation.....	6
3.1	Unpacking	6
3.2	Installation into the system	6
3.3	Connections	6
3.3.1	Safety Low Voltage Control (20 .. 28 V DC).....	7
3.3.2	Line Voltage Control (100 .. 240 V AC) without Position Indicator	7
3.3.3	Line Voltage Control (100 .. 240 V AC) with Position Indicator	8
3.3.4	Operation under increased temperature	8
3.4	Behavior in case of power failure	8
4	Trouble shooting	8
5	Maintenance & repairs	9
5.1	Replacement of Seals	9
6	Drawing.....	11
7	Spare parts	11
8	Warranty	12



1 Use of product

Use product for clean and dry indoor vacuum applications under the conditions indicated in chapter «Technical data» only!
Other applications are only allowed with the written permission of VAT.

2 Technical data

Leak rate	< $1 \cdot 10^{-9}$ mbar l s ⁻¹ (for FKM-Seals)	
Pressure range	$1 \cdot 10^{-8}$ mbar to 2 bar (abs)	
Differential pressure on the plate	≤ 2 bar	
Closing time	≤ 0.2 s	
Admissible temperature	0 - 50°C	
Maximum operating frequency	15 cycles per min at 20°C	
Cycles until first service	200'000	
Mounting position	any	
Voltage	100 .. 115 VAC or 200 .. 240 VAC; 50/60 Hz	
Power consumption:	Pick up 700 W (~100 ms) Holding 10 W	
Position indicator contact rating	max. 48 V AC / DC; max 500 mA	
Protection class	IP 40	
Overcurrent protection device	2 A, tripping characteristic „D“ (EN 60898)	
Material:		
Valve plate	AISI 316L (1.4404, 1.4435)	
Bellows	AISI 316L (1.4404, 1.4435), 316 Ti (1.4571)	
Seals	FKM (VITON) [others optional according to dimension drawing]	
Body:		
Aluminum valve	EN AW-6060 (3.3206), EN AW-6061 (3.3211), EN AW-6063 (3.3206), EN AW-6082 (3.2315)	
Stainless steel valve	AISI 304 (1.4301, 1.4305)	
Molecular Flow conductance:		
DN25	14 l/s	
DN40	45 l/s	
Weight:	Aluminum	Stainless steel
Angle Valves: DN 25	1.4 kg (3.1 lbs)	1.5 kg (3.3 lbs)
DN 40	1.8 kg (4.0 lbs)	2.0 kg (4.4 lbs)
Inline Valves: DN 25	1.5 kg (3.3 lbs)	1.5 kg (3.3 lbs)
DN 40	1.8 kg (4.0 lbs)	2.2 kg (4.9 lbs)

3 Installation

3.1 Unpacking

Before unpacking the valve, make sure that the packaging is in impeccable condition and the valve has not suffered damage.

Note! The plastic packing material and/or protective covers may only be removed immediately before the valve is mounted into the system. Unprotected sealing surfaces must be treated with care and kept clean.

3.2 Installation into the system

DN (nom. I.D.)		Axial tensile or compressive force «F _A »		Bending moment «M»	
mm	inch	N	lbf	Nm	lbf · ft
25	1	70	16	3	2.2
40	1½	100	22	6	4.5

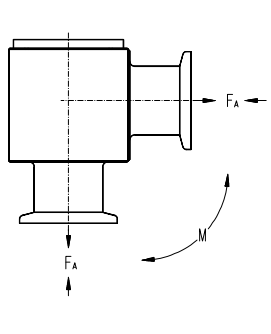
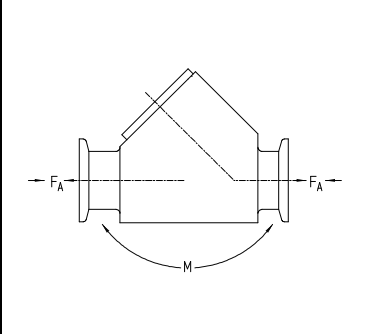
A combination of both forces «F_A» and «M» is prohibited. Please contact VAT.

3.3 Connections



Do not touch parts under voltage!



Connect electrical power only when
 - valve is installed into the system
 - moving parts cannot be touched

Make sure that the control voltage is in accordance with the voltage stated on the Valve!

Valve may only be installed by a trained professionalist according to the local technical standards and law.

The valve may operated with a maximum frequency of 15 cycles/minute.
 Higher frequency could lead to overheating of the coil.



Attention:
 Coil can reach a temperature of 70°C when continuously used. Beware of touching!

Connecting cables must not be longer than 30 m.

3.3.1 Safety Low Voltage Control (20 .. 28 V DC)

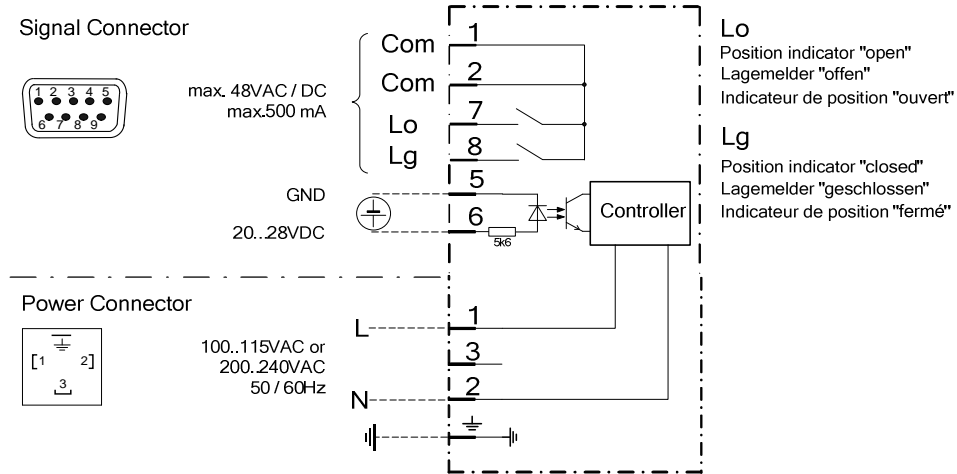

The valve requires system voltage supply at the power connector (100 .. 115 VAC or 200 .. 240 VAC - check label on valve). On the signal connector provide 20 .. 28V DC to the micro controller according to the wiring diagram to pins 5-6.

Operation:

- To open the valve, power has to be provided to pins 5 and 6
- To close the valve, power has to be switched off for pins 5 and 6

Position Indicator:

The solid state relays indicate the valve position as long as power is provided to the power connector. In addition the LED's indicate the position of the valve (green for valve open; orange for valve closed)

3.3.2 Line Voltage Control (100 .. 240 V AC) without Position Indicator

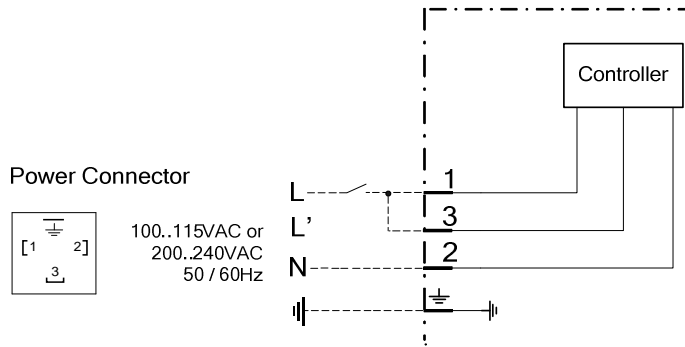

Valves are available for 100 .. 115 VAC and 200 .. 240 VAC (check label on valve).

Operation:

- To open the valve, power has to be provided to N and both L and L'.
- To close the valve, power has to be switched off for L' and L.

Position Indicator:

The green LED will indicate the open valve position. After switching off the power, the orange LED might indicate the closed valve position, but the light will fade out shortly afterwards.

Note: This connection diagram can be used to replace valves in case no L' signal is available.

3.3.3 Line Voltage Control (100 .. 240 V AC) with Position Indicator

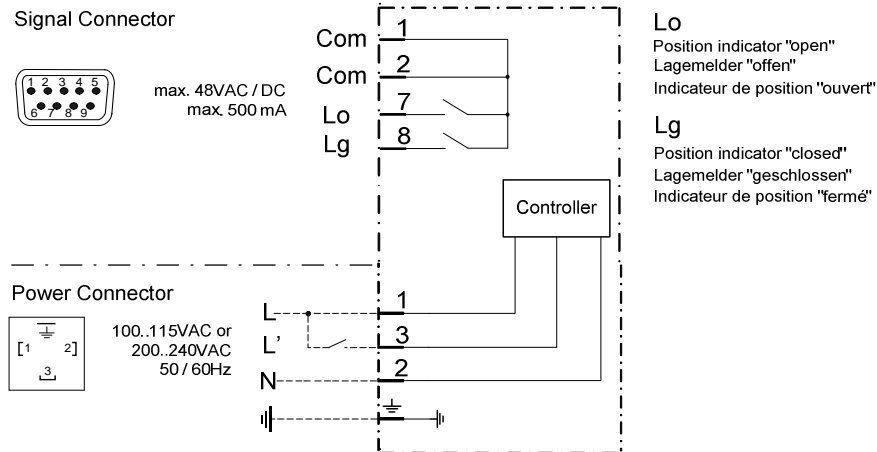

Valves are available for 100 .. 115 VAC and 200 .. 240 VAC (check label on valve).

Operation:

- To open the valve, power has to be provided to N and both L and L'.
- To close the valve, power has to be switched off for L'.

Position Indicator:

The solid state relays indicate the valve position as long as power is provided to the power connector. In addition the LED's indicate the position of the valve (green for valve open; orange for valve closed)

3.3.4 Operation under increased temperature

See «2 Technical data»



Attention !

Coil of magnet can reach a temperature of 70° C when continuously used. Beware of touching!

3.4 Behavior in case of power failure

Valve closes
 Both position indicator relays are open, LEDs are off.

4 Trouble shooting

Failure	Check	Action
Valve does not operate	Confirm correct installation	Install valve correctly
	Confirm correct power on connectors	Provide correct power
Position Indicator are flashing alternant	Check cycle frequency of the valve	Wait, valve will operate as soon as frequency is in correct range
	Check if valve movement is interfered by any object	Remove object and clean valve

If you need any further information, please contact one of our service centers. You can find the addresses on our website: <http://www.vat.ch>

5 Maintenance & repairs

Under clean operating conditions, the valve does not require any maintenance during the specified cycle life. Contamination from the process may influence the function and requires more frequent maintenance.

Before carrying out any maintenance or repairs, please contact VAT. It has to be individually decided whether the maintenance/repair can be performed by the customer or has to be carried out by VAT. The Serial / Fabrication number on the valve

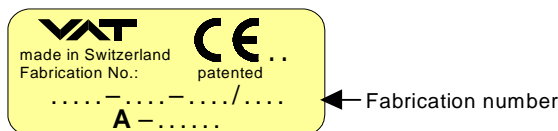

has always to be specified.

All supplies (e. g. compressed air, electrical power) must be disconnected for removal/installation of the valve from/into the system and for maintenance work.



Even with disconnected supply, loaded springs and/or air cushions in cylinders can be potential hazards.



Keep fingers and objects away from the valve opening!

Products returned to VAT must be free of harmful substances such as e.g. toxic, caustic or microbiological ones. If products are radioactively contaminated, fill in the VAT form «Contamination and Radiation Report» and send it with the product. The form is available at VAT. The maximum values indicated in the form must not be exceeded.

5.1 Replacement of Seals

The item numbers in brackets refer to the drawing on page 11

- Remove power connector and signal connector
- Remove screw 27, coil assembly 26 and O-Ring 18
- Remove 4 screws 60 Remove bonnet flange 16
- Withdraw axial conduit 17 with O-Ring 63
- Withdraw complete valve insert with bellows from body
- Remove O-ring 62
- Stick a needle into the O-ring 61 and pull it out of groove
Attention: Do not damage the sealing surface!
- Clean all sealing surfaces and contaminated parts



- Put new O-ring 61 on plate groove and press it crosswise into groove at 4 points
- Press O-ring 61 uniformly into groove
- Put new bonnet seal (O-ring, 62) into body
- Insert complete valve insert with bellows into body.
- Insert O-Ring 63 and axial conduit 17
- Insert bonnet flange 16 carefully. Do not cant!
- Fasten 4 screws 60 uniformly and crosswise in 2 to 3 steps
- Attach O-Ring 18 and coil assembly 26
- Fasten screw 27 (D = 6 Nm)
- Attach power connector and signal connector.

6 Drawing

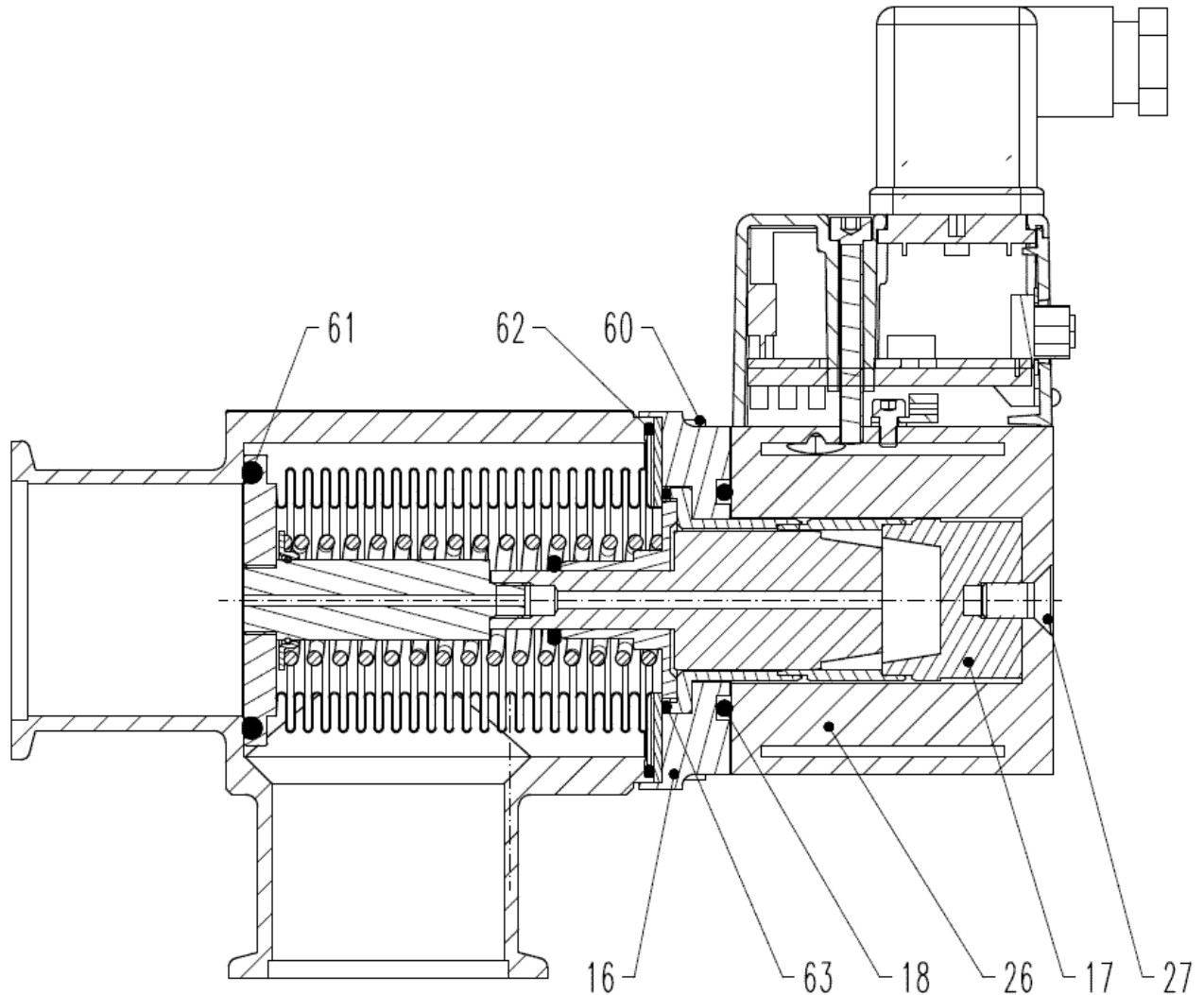

7 Spare parts



Please specify the **Serial / Fabrication number of the valve** (see yellow label on valve) when ordering spare parts. This is to ensure that the appropriate spare parts are supplied.

Item	Description	Extras
61, 62, 63	Seal Kit	
26	Coil with Electronics	



8 Warranty

Each product sold by VAT Vakuumventile AG (VAT) is warranted to be free from the manufacturing defects that adversely affect the normal functioning thereof during the warranty period stated in VAT's «Terms of Sale» immediately following delivery thereof by VAT, provided that the same is properly operated under conditions of normal use and that regular, periodic maintenance and service is performed or replacements made, in accordance with the instructions provided by VAT. The foregoing warranty shall not apply to any product or component that has been repaired or altered by anyone other than an authorized VAT representative or that has been subject to improper installation or abuse, misuse, negligence or accident. VAT shall not be liable for any damage, loss, or expense, whether consequential, special, incidental, direct or otherwise, caused by, arising out of or connected with the manufacture, delivery (including any delay in or failure to deliver), packaging, storage or use of any product sold or delivered by VAT shall fail to conform to the foregoing warranty or to the description thereof contained herein, the purchaser thereof, as its exclusive remedy, shall upon prompt notice to VAT of any such defect or failure and upon the return of the product, part or component in question to VAT at its factory, with transportation charges prepaid, and upon VAT's inspection confirming the existence of any defect inconsistent with said warranty or any such failure, be entitled to have such defect or failure cured at VAT's factory and at no charge therefor, by replacement or repair of said product, as VAT may elect. VAT MAKES NO WARRANTY OR REPRESENTATION OF ANY KIND, EXPRESS OR IMPLIED, (INCLUDING NO WARRANTY OR MERCHANTABILITY), EXCEPT FOR THE FOREGOING WARRANTY AND THE WARRANTY THAT EACH PRODUCT SHALL CONFORM TO THE DESCRIPTION THEREOF CONTAINED HEREIN, and no warranty shall be implied by law.

Furthermore, the «Terms of sale» at the back of the price list are applicable.