

All-Metal Angle Valve manual actuator

This manual is valid for the valve ordering number(s):
57132- . E02/05/07/08

The fabrication number is indicated on each product as per the label below (or similar):

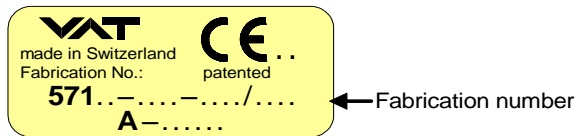

Explanation of symbols:



Read declaration carefully before you start any other action!



Keep body parts and objects away from the valve opening!



Attention!



Hot surfaces; do not touch!



Product is in conformity with EC guidelines, if applicable!



Loaded springs and/or air cushions are potential hazards!



Disconnect electrical power and compressed air lines. Do not touch parts under voltage!



Wear gloves!



Read these «**Installation, Operating & Maintenance Instructions**» and the enclosed «**General Safety Instructions**» carefully before you start any other action!



Imprint:

Manufacturer VAT Vakuumventile AG, CH-9469 Haag, Switzerland

Website
www.vatvalve.com

Phone
+41 81 771 61 61

Fax
+41 81 771 48 30

Email
CH@vatvalve.com

Publisher VAT Vakuumventile AG, CH-9469 Haag, Switzerland

Editor VAT Vakuumventile AG, CH-9469 Haag, Switzerland

Print VAT Vakuumventile AG, CH-9469 Haag, Switzerland

Copyright © VAT Vakuumventile AG 2008

No part of these Instructions may be reproduced in any way (photocopies, microfilms or any other reproduction processes) nor may it be manipulated with electronic systems, duplicated or distributed without written permission from VAT. Offenders are liable to pay damages.

The original VAT firmware and updated state of the art versions of the VAT firmware are intended for use with VAT products. The VAT firmware contains a limited, time unlimited user license. The VAT firmware may not be used for purposes other than those intended nor is it permitted to make copies of the VAT firmware. In particular, it is strictly forbidden to give copies of the VAT firmware to other people.

The use of trade names, brand names, trademarks, etc. in these Instructions does not entitle third parties to consider these names to be unprotected and to use them freely. This is in accordance with the meaning of the laws and acts covering brand names and trademarks.



Contents:

1	Use of product.....	4
1.1	Technical data.....	4
2	Installation.....	4
2.1	Electrical connection (valves with position indicator).....	5
2.1.1	Position indicators for max. 80°C – contact rating ≤ 50 V AC / DC; ≤ 1.2 A.....	5
2.1.2	Position indicators for max. 200°C and 300°C – contact rating ≤ 50 V AC / DC; ≤ 1 A.....	5
3	Operation.....	6
3.1	Normal operation.....	6
3.2	Bake-out.....	6
4	Trouble shooting.....	7
5	Preventive Maintenance / Repairs.....	7
5.1	Readjustment of sealing force.....	8
5.2	Instruction how to change the VATRING (Don't touch inside valve parts without gloves).....	8
5.3	Adjustment of closing torque / assembly hexagon head (valve insert installed in the valve body).....	9
6	Drawing.....	10
7	Spare parts.....	11
8	Warranty.....	13

1 Use of product

Use product for clean and dry indoor vacuum applications under the conditions indicated in chapter «Technical data» only! Other applications are only allowed with the written permission of VAT.

1.1 Technical data

Leak rate: body, seat	$< 1 \cdot 10^{-10}$ mbarls ⁻¹
Pressure range	extreme UHV to 5 bar (abs)
Differential pressure on the gate	5 bar in either direction
Max. differential pressure at opening	5 bar in either direction (with reduced cycle life time)
Admissible temperature: Valve open (incl.actuator)	≤ 450°C
Valve closed (incl.actuator)	≤ 350°C
Position indicator	≤ 80°C (option: 200°C,300°C)
Position indicator: Contact rating	≤ 50 V AC / DC; ≤ 1.2 A (80°C version) ≤ 50 V AC / DC; ≤ 1 A (200°C / 300°C version)

Further data according to VAT catalogue «Vacuum Valves 2008».

2 Installation



Handling of the valve must take place under clean conditions normally observed in good vacuum practice. The valve may only be touched with clean gloves. After the protective covers have been removed, the sealing surfaces of the flanges have to be cleaned carefully with alcohol. The screws of the flanges have to be tightened uniformly in diagonal crosswise order. Determine that the valve and existing plumbing in the vacuum system will be adequately supported.

Admissible forces

The valve must not support other components and has to be protected from forces of the system (e.g. by bellows sections).

2.1 Electrical connection (valves with position indicator)



Do not touch electrical parts under voltage!



Connect electrical power only if
 - valve is installed into the vacuum system
 - moving parts cannot be touched

The suitable sockets are supplied with the valve.

Wiring diagrams:

2.1.1 Position indicators for max. 80°C – contact rating ≤ 50 V AC / DC; ≤ 1.2 A

	<p>Standard position indicator with make contact switches</p> <p>Lo = position indicator «open» Lg = position indicator «closed»</p>	<p>Double position indicator with make contact switches - two each (option)</p> <p>Lo = position indicator «open» Lg = position indicator «closed»</p>
	<p>Position indicator with double throw switches (option)</p> <p>Lo = position indicator «open» Lg = position indicator «closed»</p>	<p>Double position indicator with double throw switches - two each (option)</p> <p>Lo = position indicator «open» Lg = position indicator «closed»</p>

2.1.2 Position indicators for max. 200°C and 300°C – contact rating ≤ 50 V AC / DC; ≤ 1 A

	<p>Single position indicator (option)</p> <p>Lo = position indicator «open» Lg = position indicator «closed»</p>	<p>Double position indicator (option)</p> <p>Lo = position indicator «open» Lg = position indicator «closed»</p>
--	---	---

3 Operation

3.1 Normal operation

Opening of closed valve

- turn hexagon head counter clockwise to it's stop. The valve is completely open when the stop is reached.

Closing of open valve

- turn hexagon head clockwise to it's stop. The valve is completely closed and leaktight when it's mechanical stop is reached.

Don't overtorque!



The sealing force of the valve can't be increased with a higher torque. The force to seal the valve is supplied by a spring. The mechanical stop is reached before the spring is completely loaded.

	Nominal I.D. (DN)
	DN 40
Hexagon head wrench size	17mm
Cylindrical head diameter	Ø14mm
required torque for closing * (adjusted by VAT)	12 Nm

* May slightly rise due to bakeouts.

Valves with hexagon head may be operated by ring or fork wrench or by using a hand wheel (see spare parts list).
Valves with cylindrical head have to be operated by a hand wheel with free wheel option (see spare parts list).

3.2 Bake-out

Valve open (incl.actuator)	≤ 450°C
Valve closed (incl.actuator)	≤ 350°C
Position indicator:	≤ 80°C (option: 200°C, 300°C)
Heating and cooling rate:	60°C/h

Temperature differences exceeding 60°C throughout the valve are not allowed. They may affect the performance of the valve.

4 Trouble shooting

If you need any further information, please contact one of our service centers. You can find the addresses on our website: <http://www.vat.ch>

5 Preventive Maintenance / Repairs

Under clean operating conditions, the valve does not require any maintenance during the specified cycle life. Contamination from the process may influence the function and requires more frequent maintenance.

Before carrying out any maintenance or repairs, please contact VAT. It has to be individually decided whether the maintenance/repair can be performed by the customer or has to be carried out by VAT. The fabrication number on the valve

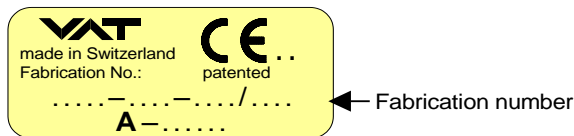

has always to be specified.

All supplies (e. g. compressed air, electrical power) must be disconnected for removal/installation of the valve from/into the system and for maintenance work.



Even with disconnected supply, loaded springs and/or air cushions in cylinders can be potential hazards.



Keep fingers and objects away from the valve opening!

Products returned to VAT must be free of harmful substances such as e.g. toxic, caustic or microbiological ones. If products are radioactively contaminated, fill in the VAT form «Contamination and Radiation Report» and send it with the product. The form is available at VAT. The maximum values indicated in the form must not be exceeded.



5.1 Readjustment of sealing force

- Close the valve to mechanical stop
- Remove slotted rollpin (together with dowel pin) at the hexagon head
- Turn the hexagon head slightly counter clockwise back by one hole
- Press in slotted rollpin (together with dowel pin) again
- close the valve to mechanical stop

5.2 Instruction how to change the VATRING (Don't touch inside valve parts without gloves)

The item numbers refer to the drawing on page 9.

- Open the valve and loosen bonnet screws (68)
- Remove valve insert and bonnet seal (36/2)
- When loosening and tightening the screw (67) protect the bellows against torsion with hole \varnothing 2.6
- Remove VATRING
- Take a lint free tissue dabbed with alcohol and clean all sealing surfaces (plate, bonnet, body - seat and bonnet, VATRING)
- Check sealing surfaces (visually) for scratches
- Clean VATRING and plate with cleaned and dry compressed air
- Place VATRING on sealing surface of the plate
- Place holding ring on top of plate
- Align VATRING parallel with the plate
- Insert screw (67), protect bellows against turning, tighten screw (torque according to below list)
- Place new bonnet seal (36/2) exactly like shown on next page (fitting position) !
- Put valve insert back into valve body and tighten screws in diagonal crosswise order (torque according to below list)

	Nominal ID (DN)
	DN 40
closing torque of VATRING screw (67)	7 Nm
closing torque of bonnet screw (68)	7 Nm

5.3 Adjustment of closing torque / assembly hexagon head (valve insert installed in the valve body)

New actuator components:

Note this procedure works only for unused actuator components. As soon as the parts are baked the required closing torque will raise and the torque adjustment would end in a to small sealing force.

- Place hexagon head (1) – (Fig. 2A) - on the spindle (2) and fix it with a pin (3) \varnothing 4mm at the diameter 16 mm
- Close the valve and do 10 cycles with a torque of 14 to 15 Nm. Then go back to open position
- Close the valve with a torque of 10Nm
- Remove the pin (3) \varnothing 4mm, now turn by hand the hexagon head (1) clockwise its mechanical stop - (Fig. 2B).
- Turn the hexagon head (1) slightly counter clockwise until the first hole (5) of hexagon head (1) reaches the slot of the spindle (6) - (Fig. 2C)
- Put dowel pin (7) into slotted rollpin (8) so that the slits (9) of them are opposite to each other. Then press them as one piece trough the hole of hexagon head (5) and slot in the spindle (6) - (Fig. 2D)

Allready used (and baked) actuator components:

- First measure required closing torque to come to mechanical stop
- Perform repair work (eg. Replace VATRING)
- Assemble valve again
- Release hexagonal head
- Place hexagon head (1) - (Fig. 2A) - on the spindle (2) and fix it with a pin (3) \varnothing 4mm at the diameter 16 mm
- Close the valve with previous measured closing torque
- Remove the pin (3) \varnothing 4mm, now turn by hand the hexagon head (1) clockwise to its mechanical stop - (Fig. 2B)
- Turn the hexagon head (1) slightly counter clockwise until the first hole (5) of hexagon head reaches the slot of the spindle (6) - (Fig. 2C)
- Put dowel pin (7) into slotted rollpin (8) so that the slits (9) of them are opposite to each other. Then press them as one piece trough the hole of hexagon head (5) and slot in the spindle (6) - (Fig. 2D)

Figure 2

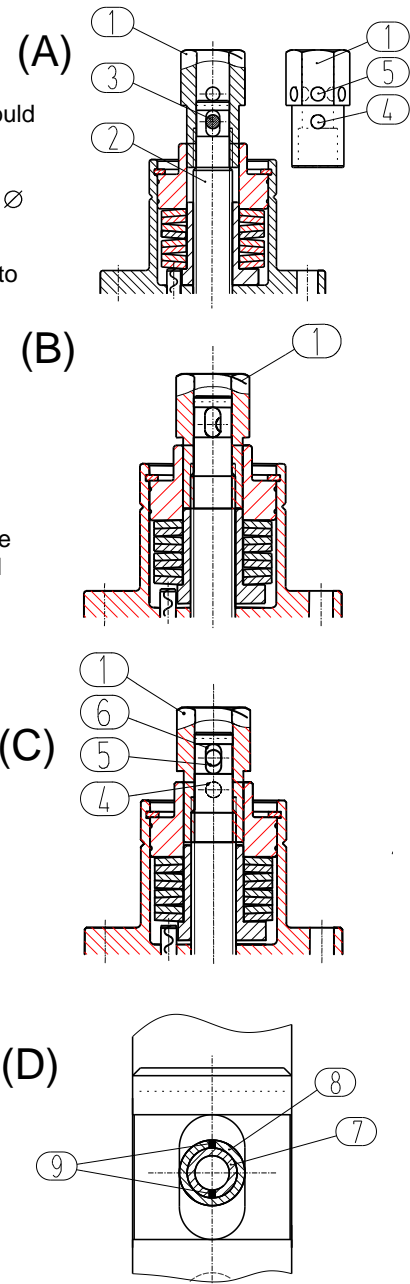

6 Drawing

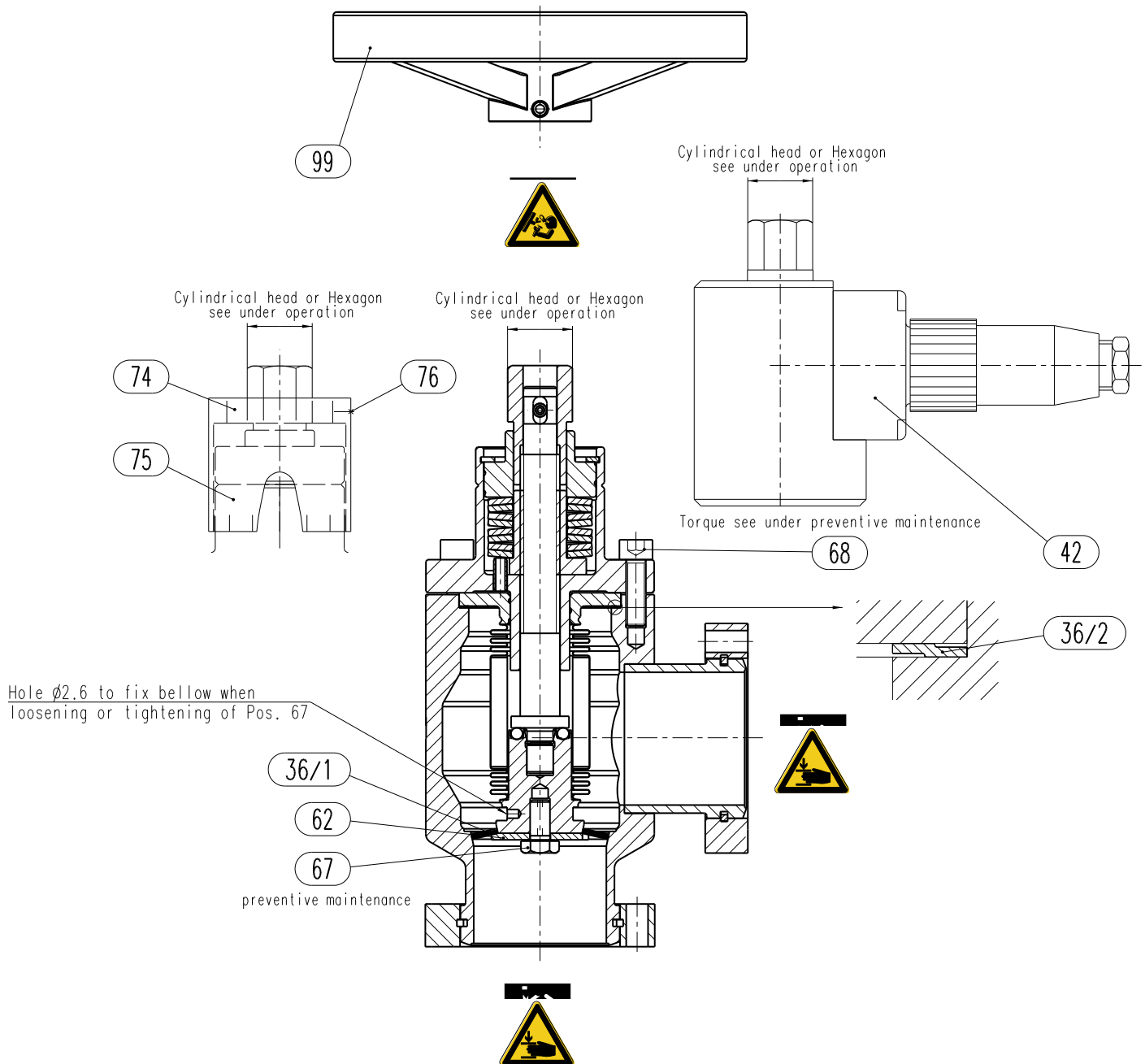



7 Spare parts



Please specify the **fabrication number of the valve** (see yellow label on valve) when ordering spare parts. This is to ensure that the appropriate spare parts are supplied.

The item numbers refer to the drawing on page 10.

Item	Description	Qty	Part / Ordering number
			DN 40
36/1	VATRING	1	42372-01
36/2	Bonnet seal	1	90367-01
62	Holding ring	1	93854-01
67	Screw with venting hole	1	N-5002-052
68	Treated hexagon socket head cap screw	6	N-5019-790
99	Hand wheel for hexagon head	1	96866-R1
99	Hand wheel for cylindrical head	1	93857-R1
74	Ring	1	100322-01
75	Scale	1	100323-01
76	Screw	5	N-6071-459
	Vacuum seal kit, consisting of VATRING and bonnet seal	1	(90368-R1)

Position indicators 80°C (single + double) in various versions

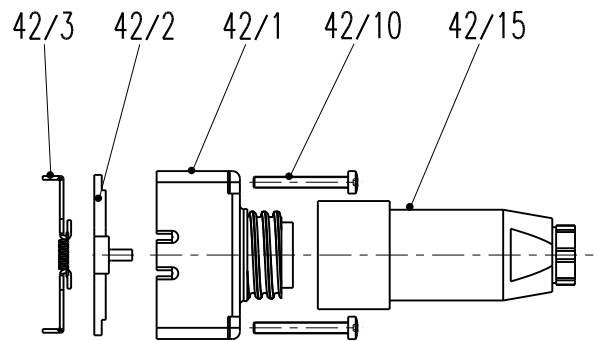

Item	Description	Version	Qty.		Part No.
			single	double	
42	BS Mini position indicator	make contact switches	1	2	69250-R1
		double throw switches	1	2	75430-R1
		make contact radiation resistant	1	2	90471-R1
		double throw radiation resistant	1	2	91701-R1
42/1	Position indicator	make contact switches	1	2	71852-R1
		double throw switches	1	2	70606-R1
		make contact radiation resistant	1	2	80075-R1
		double throw radiation resistant	1	2	83954-R1
42/2	Slider		1	2	69846-01
42/3	Driving piece		1	2	69428-R1
42/10	Screw		4	8	N-6016-078
42/15	Socket		1	2	N-8504-002

Position indicators 200°C (single)

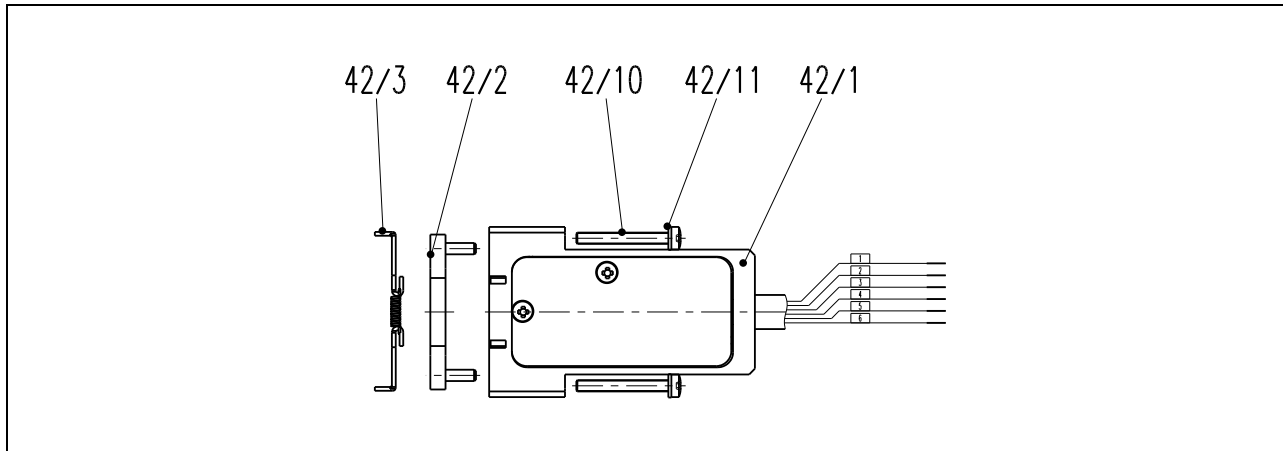

Item	Description	Version	Qty.	Part No.
			single	
42	BS Mini position indicator	double throw switches 200°C	1	330085
42/1	Position indicator		1	241824
42/2	Slider		1	241825
42/3	Driving piece		1	69428-R1
42/10	Screw		4	N-6024-531
42/11	Spring ring		4	N-6160-406

8 Warranty

Each product sold by VAT Vakuumentile AG (VAT) is warranted to be free from the manufacturing defects that adversely affect the normal functioning thereof during the warranty period stated in VAT's «Terms of Sale» immediately following delivery thereof by VAT, provided that the same is properly operated under conditions of normal use and that regular, periodic maintenance and service is performed or replacements made, in accordance with the instructions provided by VAT. The foregoing warranty shall not apply to any product or component that has been repaired or altered by anyone other than an authorized VAT representative or that has been subject to improper installation or abuse, misuse, negligence or accident. VAT shall not be liable for any damage, loss, or expense, whether consequential, special, incidental, direct or otherwise, caused by, arising out of or connected with the manufacture, delivery (including any delay in or failure to deliver), packaging, storage or use of any product sold or delivered by VAT shall fail to conform to the foregoing warranty or to the description thereof contained herein, the purchaser thereof, as its exclusive remedy, shall upon prompt notice to VAT of any such defect or failure and upon the return of the product, part or component in question to VAT at its factory, with transportation charges prepaid, and upon VAT's inspection confirming the existence of any defect inconsistent with said warranty or any such failure, be entitled to have such defect or failure cured at VAT's factory and at no charge therefor, by replacement or repair of said product, as VAT may elect. VAT MAKES NO WARRANTY OR REPRESENTATION OF ANY KIND, EXPRESS OR IMPLIED, (INCLUDING NO WARRANTY OR MERCHANTABILITY), EXCEPT FOR THE FOREGOING WARRANTY AND THE WARRANTY THAT EACH PRODUCT SHALL CONFORM TO THE DESCRIPTION THEREOF CONTAINED HEREIN, and no warranty shall be implied by law.

Furthermore, the «Terms of sale» at the back of the price list are applicable.