



VAT Vakuumentile AG
CH-9469 Haag, Schweiz

Product data sheet

Control angle Valve Series 620, DN 40-50

Description

This product is a control angle valve with isolation function.
It is intended to be used for downstream pressure control applications in vacuum systems.

This Product Data Sheet is valid for the valve ordering number(s):

DN		Ordering numbers					
mm	inch	ISO-KF aluminum			ISO-KF stainless steel		
40	1½	62032-KA	x	y	62032-KE	x	y
50	2	62034-KA	x	y	62034-KE	x	y

Controller configurations:

Controller configurations:		Interface	Sensor inputs
G = Basic version		H = RS232	2
A = with SPS		E = Logic (A/D)	2
H = with PFO		Q = DeviceNet®	2
C = with SPS and PFO		F = Profibus	2
		K = RS485	2
		Z = Ethernet *	2
		N = CC-Link	2
		X = EtherCAT	2
		Z = Ethernet	2

SPS=	Sensor Power Supply (±15VDC power for sensor)
PFO=	Power Failure Option (valve closes / opens automatically at power failure)

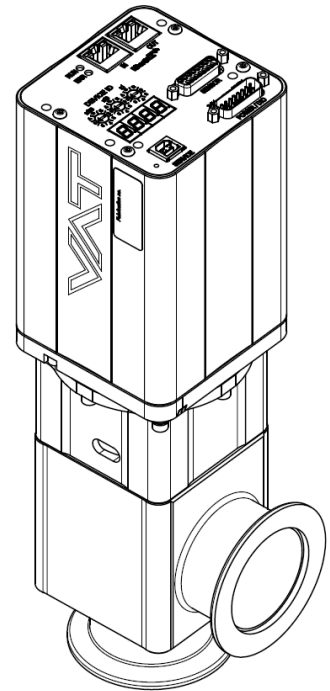

Sample picture only. Specified product may differ in size, flange and options.

Example:

62034-KEGX = stainless steel valve with ISO-KF DN 50 flange, EtherCAT interface, 2 sensor inputs

Created by: DACM	Release date: 22.07.2022	1/8
Modified by:	Release date:	941229ED



VAT Vakuumventile AG
CH-9469 Haag, Schweiz

Product data sheet

Control angle Valve Series 620, DN 40-50

Technical data

Valve unit

Pressure range at 20°C		(unheated on delivery)
- Aluminum and Stainless steel		1 × 10 ⁻⁸ mbar to 1.4 bar (abs)
Leak rate to outside (global) at 20°C		(unheated on delivery)
- Aluminum and Stainless steel		1 × 10 ⁻⁹ mbar ls ⁻¹
Leak rate seat at 20°C		(unheated on delivery)
- Aluminum and Stainless steel		1 × 10 ⁻⁹ mbar ls ⁻¹
<p>Note: This valve is normally equipped with a brake to assure the leak rate without electrical power supply. In case the brake is not included due to customization, the leak rate is assured during electrical power supply only.</p>		
Cycles until first service		(under clean conditions)
≤ 80°C		
• throttling (open – min. conductance – open)		2'000'000
• isolation (min. conductance – close – min. conductance)		1'000'000
≤ 200°C		
• throttling (open – min. conductance – open)		1'000'000
• isolation (min. conductance – close – min. conductance)		500'000
Admissible operating temperature		
• Valve body / bellows / plate	standard version	≤ 80°C
	high temp version	≤ 150°C (with standard FKM seals e.g. Viton®) ≤ 200°C (with optional FFKM seals)
• Controller ambient		≤ 50°C (< 35°C recommended)
Mounting position		any (valve seat on chamber side is recommended)
Process side materials	body	Aluminum EN AW-6082 (3.2315) or Stainless steel AISI 316L (1.4404 or 1.4435)
	plate	Stainless steel AISI 316L (1.4404 or 1.4435)
	bellows	Stainless steel AISI 316L (14571)
	bellows end piece	Stainless steel AISI 316L (1.4404 or 1.4435)
Seals	plate	FKM (e.g. Viton®)
	bonnet	FKM (e.g. Viton®)

Created by: DACM	Release date: 22.07.2022	2/8
Modified by:	Release date:	941229ED



VAT Vakuumentile AG
CH-9469 Haag, Schweiz

Product data sheet

Control angle Valve Series 620, DN 40-50

DN (nominal I. D.)	[mm]	40	50
	[inch]	1½"	2"
Max. differential pressure on plate (during operation)	[mbar]	1000	1000
Max. differential pressure on plate (isolated)	opening direction [mbar]	1000	1000
	closing direction [mbar]	1400	1400
Actuating time (typical)	Throttling (pressure / position control) 0% -> 100% 100% -> 0%	1.7 s	1.9 s
	Close 0% -> isolated 0% -> close signal 100% -> isolated 100% -> close signal	0.6 s	0.6 s
		1.1 s	1.1 s
		1.25 s	1.35 s
1.75 s		1.85 s	
Open Isolated -> 0% 0% -> 100%	0.25 s	0.25 s	
	0.65 s	0.75 s	
Stroke	[mm]	12.5	14.1
Position resolution		125'000	141'400
Min. controllable conductance (N ₂ molecular flow)	[ls ⁻¹]	0.05	0.1
Max. conductance (N ₂ molecular flow)	[ls ⁻¹]	45	80
Weight (approx.) Aluminum valve	[kg]	2.3	2.6
	[lbs]	5.1	5.8
Weight (approx.) Stainless steel valve	[kg]	3.2	3.5
	[lbs]	7.1	7.7

Created by: DACM	Release date: 22.07.2022	3/8
Modified by:	Release date:	941229ED



VAT Vakuumentile AG
CH-9469 Haag, Schweiz

Product data sheet

Control angle Valve Series 620, DN 40-50

Control unit

Power supply input	connector	D-Sub, DA-15, male
	supply voltage	+24 VDC ($\pm 10\%$) @ 0.5 V pk-pk max.
Power consumption	(control / drive)	60 W (max.) with optional SPS + 40 W with optional PFO + 10 W 3 W max. (from DeviceNet [®] to DeviceNet [®] Interface board of valve)
Ambient	temperature	0 °C to +50 °C max. (<35 °C recommended)
	humidity	0 to 95% RH, non-condensing
Interface	remote	Refer to interface
	service port	USB-B (USB 2.0)
Sensor	connector	D-Sub, DA-15, female
	number of inputs	2
	signal voltage	0 ... 10V DC with linear pressure
	input voltage range	-10 ... +10 V
	input resistance	100 k Ω
	ADC resolution	0.1 mV
	sampling rate	2 ms
	power supply (output)	+24 VDC / 1.5 A max. or ± 15 VDC / 1.2 A max. (with SPS option)
Actuator		Stepper motor, servo control
Pressure control accuracy		5 mV or 0.1% of setpoint, the higher value applies
Ingress Protection		IP 40

Created by: DACM

Release date: 22.07.2022

4/8

Modified by:

Release date:

941229ED



VAT Vakuumentile AG
CH-9469 Haag, Schweiz

Product data sheet

Control angle Valve Series 620, DN 40-50

Interface

Power Connector

Connector		D-Sub, DA-15, male
Digital inputs	input 1	interlock open (adjustable with CPA 4.0)
	input 2	interlock close (adjustable with CPA 4.0)
	voltage control contact control	12 ... 24V / 4 ... 8 mA 24V / 8 mA
Digital outputs	output 1	valve closed (adjustable with CPA 4.0)
	output 2	valve opened (adjustable with CPA 4.0)
	load	max. 70 V / 0.1 A

EtherCAT

Connector		2 x RJ45, 8-pin (socket), IN and OUT
Communication	protocol	Protocol specialized for EtherCAT
	node address	Explicit device identification or station alias, set by switches
	physical layer	100BASE-Tx (IEEE 802.3)
Cable		shielded Ethernet CAT5e or higher

DeviceNet

Connector		microstyle, 5-pin, male
Communication	protocol	DeviceNet, group 2 slave only
	data rate	125, 250, 500 kbaud by switch or network programmable
	MAC ID	address 00 - 63 by switch or network programmable
	profile	Generic "C" as default profile, Process Control Device (ODVA)
Supply voltage	transceiver at microstyle connector	24 Vnom, 11 ... 25V; max. 0.5 W

Created by: DACM	Release date: 22.07.2022	5/8
Modified by:	Release date:	941229ED



VAT Vakuumentile AG
CH-9469 Haag, Schweiz

Product data sheet

Control angle Valve Series 620, DN 40-50

RS232

Connector		D-Sub, DB-25, female
Communication settings	baud rate data bits stop bits parity bit	1200,2400,4800,9600,19200,38400,57600,115200 7 or 8 1 or 2 even, odd, none
Digital inputs	number of inputs	2
	voltage control contact control	5 ... 24V / 2 ... 10 mA 3.3V / 2 mA
Digital outputs	number of outputs	2
	load	max. 70 V / 0.1 A
Analog outputs	number of outputs	2
	voltage range	0 ... 10V
	load	max. 1 mA

RS485

Connector		D-Sub, DB-25, female
Communication settings	baud rate data bits stop bits parity bit topology network adress range	1200,2400,4800,9600,19200,38400,57600,115200 7 or 8 1 or 2 even, odd, none half duplex, full duplex point to point, multiple devices 0 ... 255
Digital inputs	number of inputs	2
	voltage control contact control	5 ... 24V / 2 ... 10 mA 3.3V / 2 mA
Digital outputs	number of outputs	2
	load	max. 70 V / 0.1 A
Analog outputs	number of outputs	2
	voltage range	0 ... 10V
	load	max. 1 mA

Created by: DACM	Release date: 22.07.2022	6/8
Modified by:	Release date:	941229ED



VAT Vakuumentile AG
CH-9469 Haag, Schweiz

Product data sheet

Control angle Valve Series 620, DN 40-50

Logic

Connector		D-Sub, DB-25, female
Digital inputs	number of inputs	8
	voltage control	5 ... 24V / 2 ... 10 mA
	contact control	3.3V / 2 mA
Digital outputs	number of outputs	4
	load	max. 70 V / 0.1 A
Analog input	number of inputs	1
	voltage range	0 ... 10V
	input resistance	100 kOhm
Analog outputs	number of outputs	2
	voltage range	0 ... 10V
	load	max. 1 mA

Profibus

Connector		D-Sub, DE-9, female
Communication	protocol	Profibus DP-V1, DP-V0
	data rate	9.6, 19.2, 45.45, 93.75, 187.5, 500 kbps, 1.5, 3, 6, 12 Mbps The baud rate is detected automatically or may be configured
	node address	SW configurable (0 – 125)

CC-Link

Connector		D-Sub, DE-9, female
Communication	protocol	CC-Link V2
	data rate	156, 625, 500 kbps, 2.5, 5, 10 Mbps SW configurable
	station number	SW configurable (1– 64)

Created by: DACM	Release date: 22.07.2022	7/8
Modified by:	Release date:	941229ED



VAT Vakuumentile AG
CH-9469 Haag, Schweiz

Product data sheet

Control angle Valve Series 620, DN 40-50

Ethernet

Connector		2 x RJ45, 8-pin (socket), IN and OUT
Communication	protocol	Telnet
	node address	IP Address (DHCP or static)
	physical layer	100BASE-Tx (IEEE 802.3)
Cable		shielded Ethernet CAT5e or higher

General data

Weight	refer to Technical Data
Dimensional drawing	Refer to dimensional drawing of specific valve ordering number (available on request)

Created by: DACM	Release date: 22.07.2022	8/8
Modified by:	Release date:	941229ED