

Revision  
Customer number

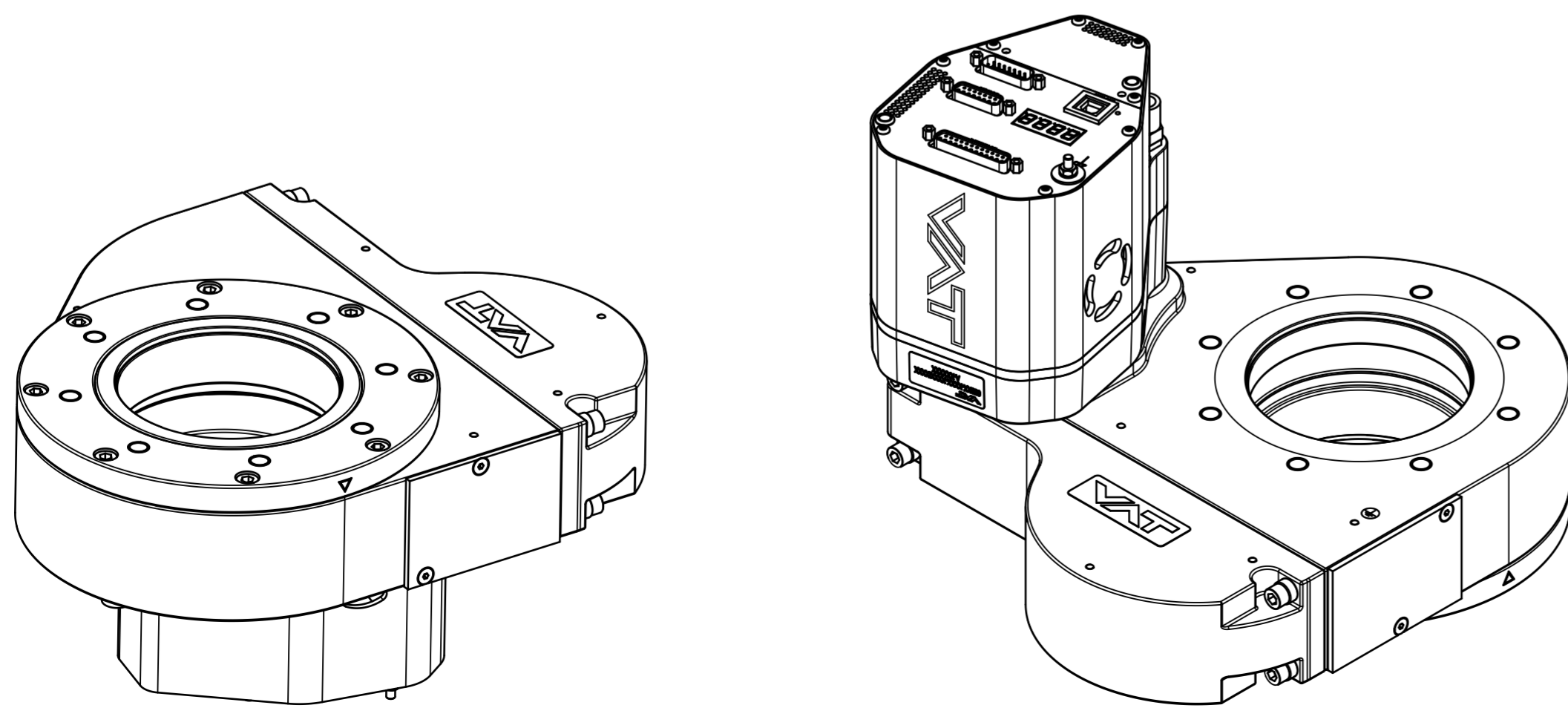

Connectors		
	Description	Type
POWER / DIO	Power input / digital IO	D-SUB DA-15 (male)
SENSOR	Sensor input Sensor power supply	D-SUB DA-15 (female)
SERVICE	Service interface	USB type-B
INTERFACE	RS232 interface	D-SUB DB-25 (female)

- ▶ Seat side
- ◀ Comp. air connection
- ⊕ Electrical connection
- ⊖ Leak detection port
- ⊙ Mech. pos. indication
- ⊙ Position indicator
- ⊙ Required for dismantling
- ⊙ Emergency actuation
- ⊙ For attachment
- ⊙ Bake-out area
- ⊙ Differential pumping port

**Control pendulum valve**  
RS232 interface / 2 sensors



VAT Vakuumventile AG  
CH-9469 Haag, Switzerland  
Tel ++41 81 7716161 Fax ++41 81 7714830

Series	653	Ordering No.	65340-PAGH-0001
Projection E	DN	Flange	ISO-F
Dimensional Drawing	100	Rev.	C