

This drawing is the property of VAT.

Revision

Customer number

SECTION A-A VALVE CLOSED

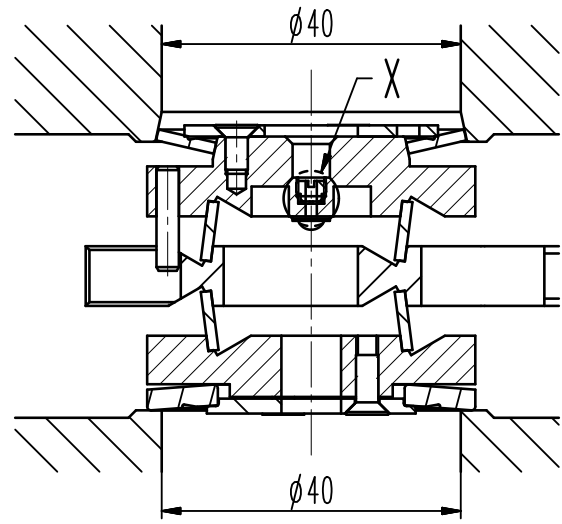

DETAIL X

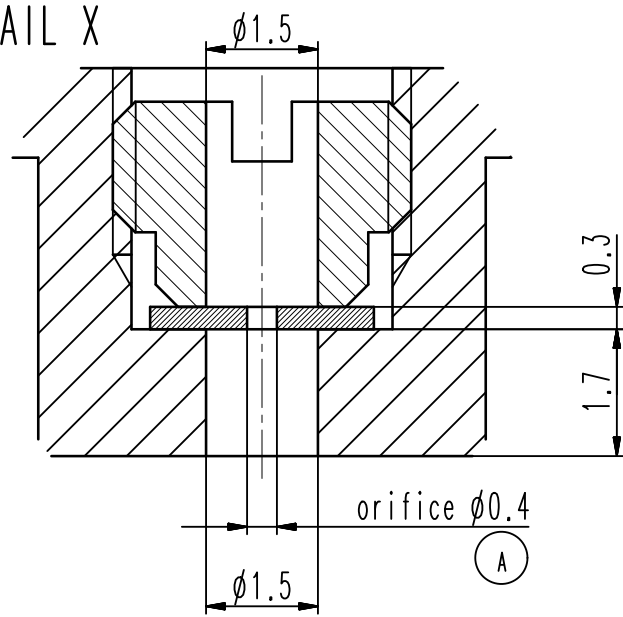

Customer can turn position indicator 90°

Delivered valve from VAT

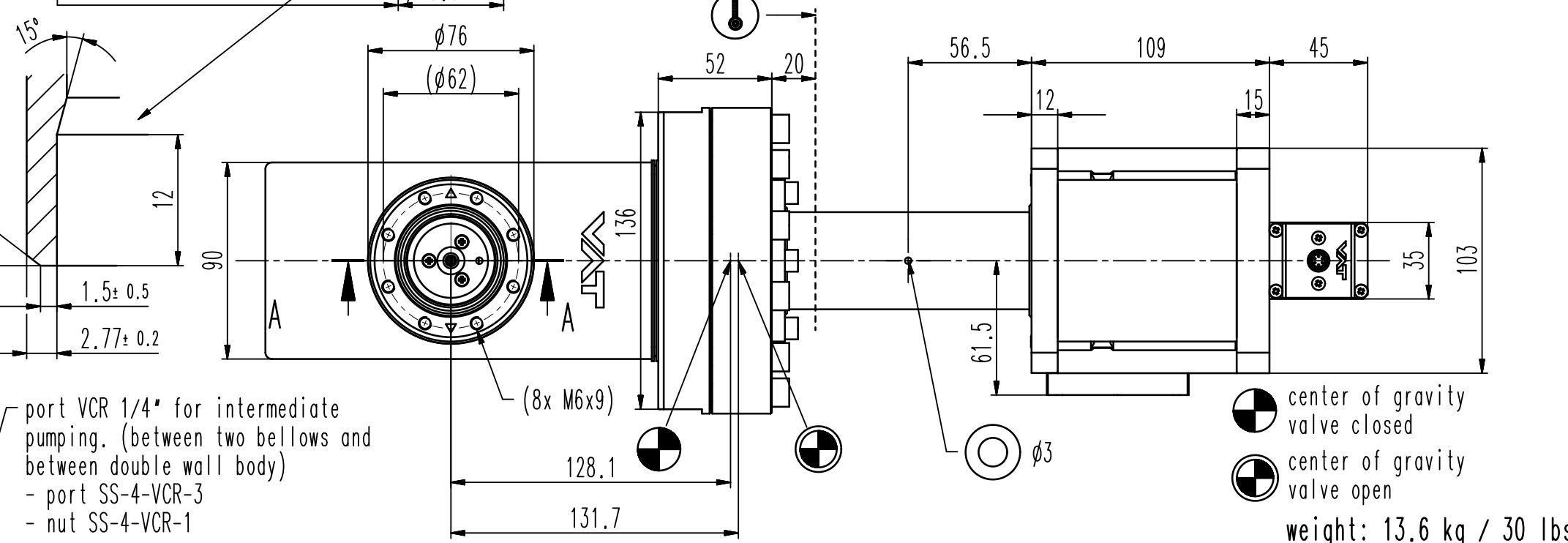
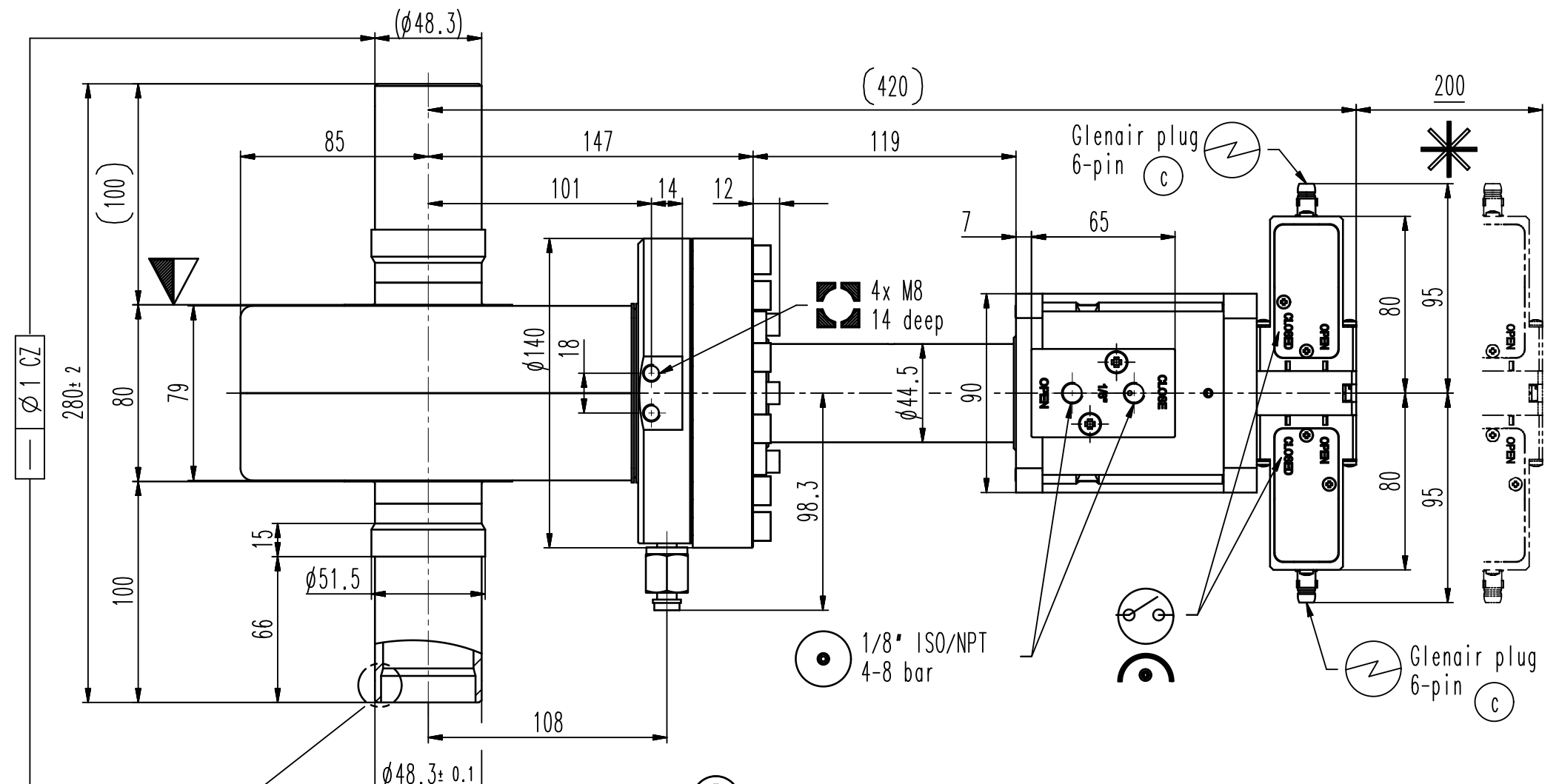
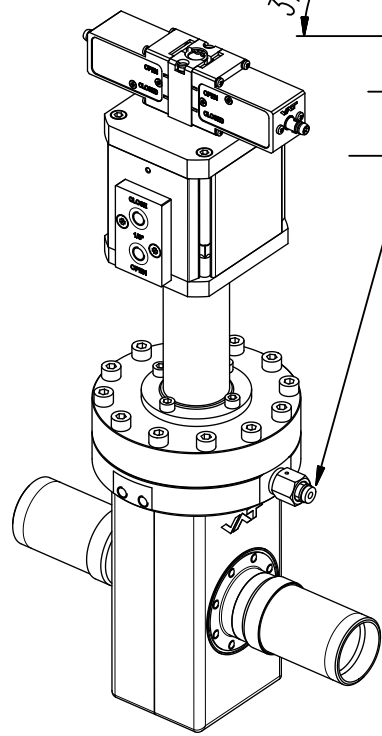
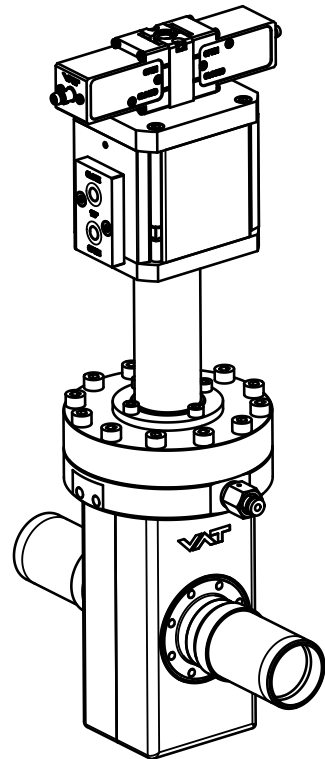

port VCR 1/4" for intermediate pumping. (between two bellows and between double wall body)
 - port SS-4-VCR-3
 - nut SS-4-VCR-1

center of gravity valve closed
 center of gravity valve open
 weight: 13.6 kg / 30 lbs

- ▽ Seat side
- ⊙ Comp. air connection
- ⊙ Electrical connection
- ⊙ Leak detection port
- ⊙ Mech. pos. indication
- ⊙ Position indicator
- ⊙ Required for dismantling
- ⊙ Emergency actuation
- ⊙ For attachment
- ⊙ Bake-out area
- ⊙ Differential pumping port

All-metal gate valve
 product: valve typ ITER 1; flange A+B; ; weld stub flange:
 Schedule No. 10S; plate: orifice 0.4 mm; position indicator:
 style rotatable 90°;

VAT Vakuumentile AG
 CH-9469 Haag, Switzerland
 Tel ++41 81 7716161 Fax ++41 81 7714830

Rev.-Date: 12.05.20
 Visa: MAT

Series	481	Ordering No.	48132-RE24-ATW1
Projection E	DN	Flange	R
Dimensional Drawing	40		
		947769	Rev. C