

This drawing is the property of VAT.

Revision

Customer number

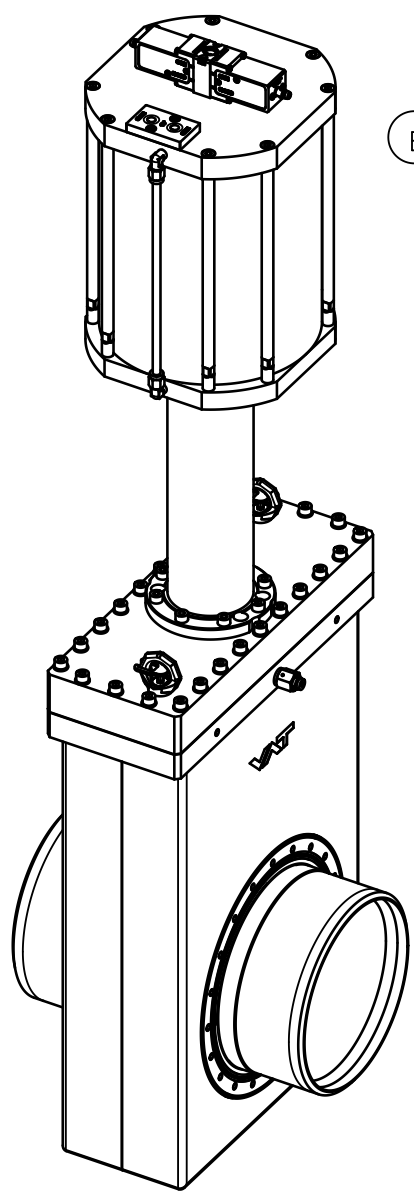
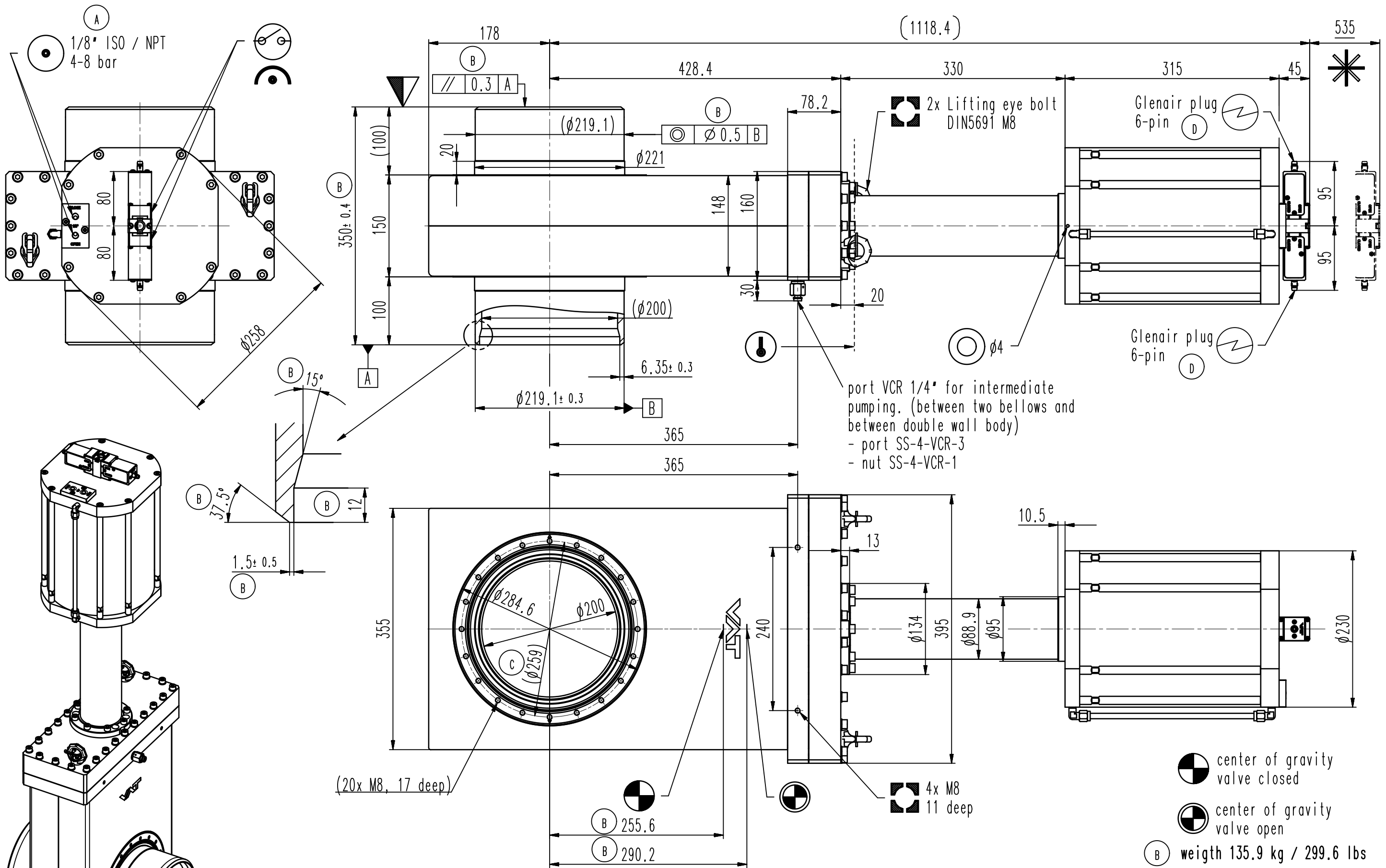

- center of gravity valve closed
- center of gravity valve open
- B** weight 135.9 kg / 299.6 lbs

- Seat side
- Comp. air connection
- Electrical connection
- Leak detection port
- Mech. pos. indication
- Position indicator
- Required for dismantling
- Emergency actuation
- For attachment
- Bake-out area
- Differential pumping port

All-metal gate valve
 product: valve typ ITER 1; flange A+B; ; weld stub flange:
 Schedule No. 20S; **A B**

VAT VAT Vakuumventile AG
 CH-9469 Haag, Switzerland
 Tel ++41 81 7716161 Fax ++41 81 7714830

Rev.-Date: 19.05.20
 Visa: MAT

Series	481	Ordering No.	48146-RE24-ARH1 B
Projection E		DN	200
Flange			R
Dimensional Drawing			478506
Rev.			D