

This drawing is the property of VAT.

Revision

Customer number

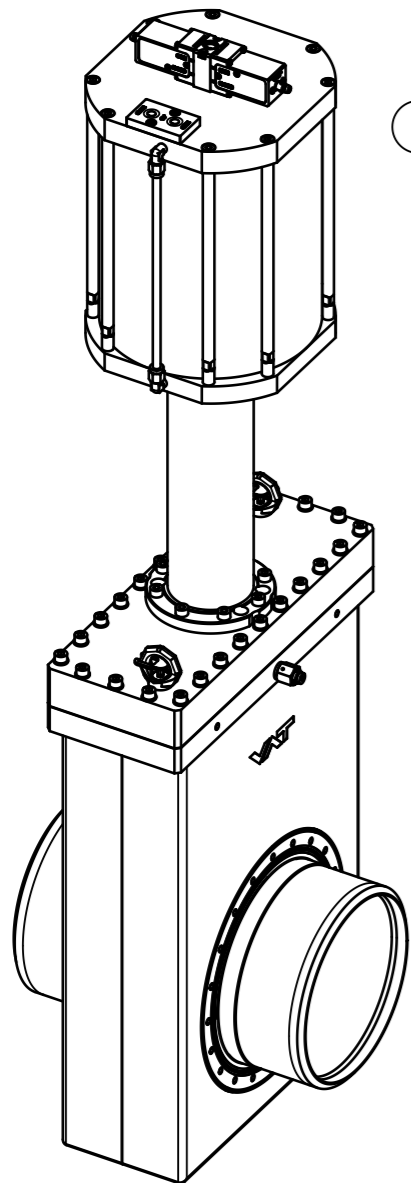
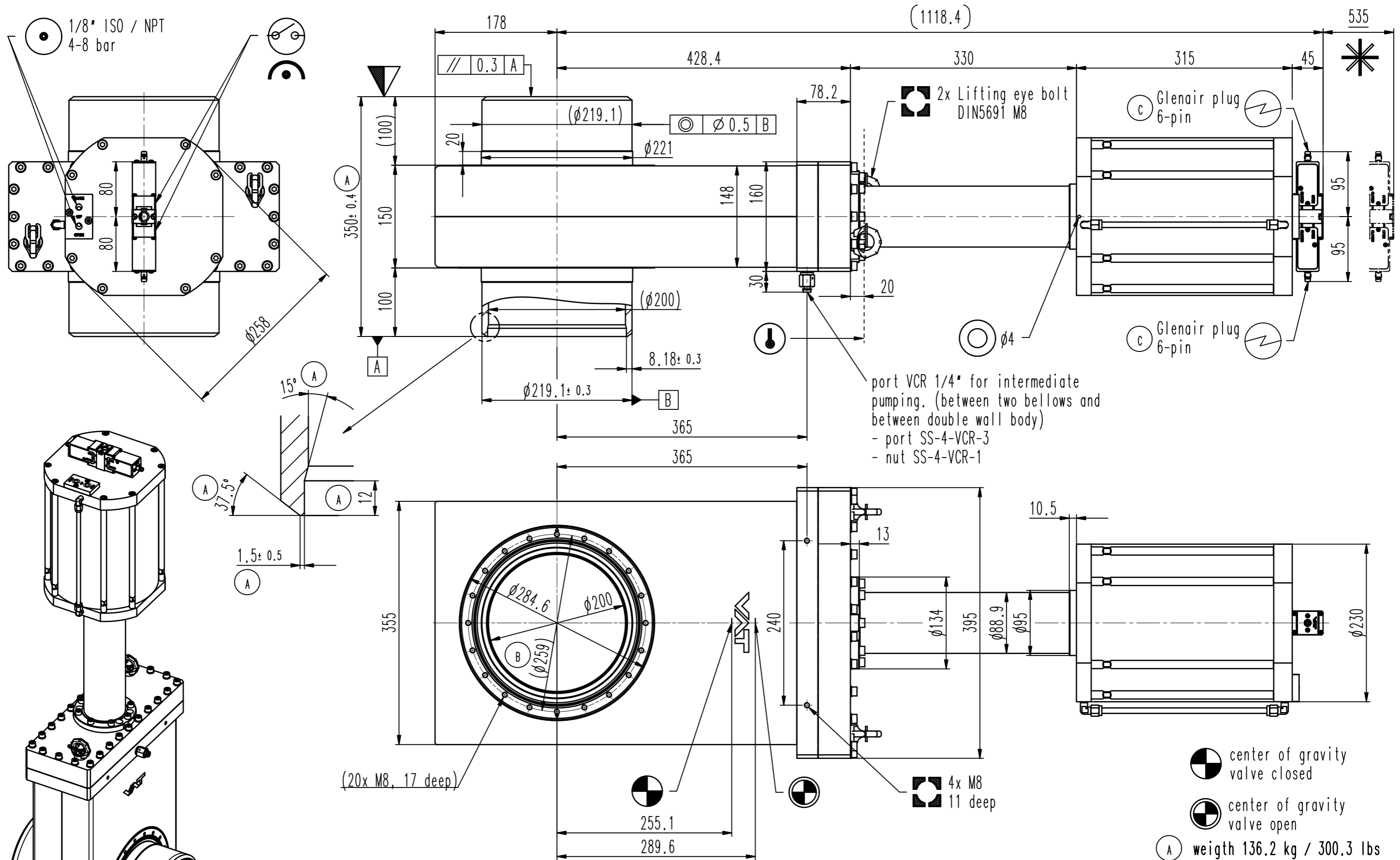

- ▼ Seat side
- ⊙ Comp. air connection
- ⊙ Electrical connection
- ⊙ Leak detection port
- ⊙ Mech. pos. indication
- ⊙ Position indicator
- ⊙ Required for dismantling
- ⊙ Emergency actuation
- ⊙ For attachment
- ⊙ Bake-out area
- ⊙ Differential pumping port

All-metal gate valve

product: valve typ ITER 1; flange A+B; ; weld stub flange:
Schedule No. 40S; A

VAT VAT Vakuumventile AG
CH-9469 Haag, Switzerland
Tel ++41 81 7716161 Fax ++41 81 7714830

Rev.-Date: 19.05.20
Visa: MAT

Series	481	Ordering No.	48146-RE24-AR11 A
Projection E	DN	Flange	R
Dimensional Drawing	200		
	750924		Rev. C