

All-metal angle valve with single acting pneumatic actuator with closing spring

Series 570 / 571
DN 40 – 63 mm (l. D. 1½" – 2½")

This manual is valid for the following product ordering number/s:

With weld stubs

57132-RE21-AJD . / AJE .
57036-RE21-AJD . / AJE .

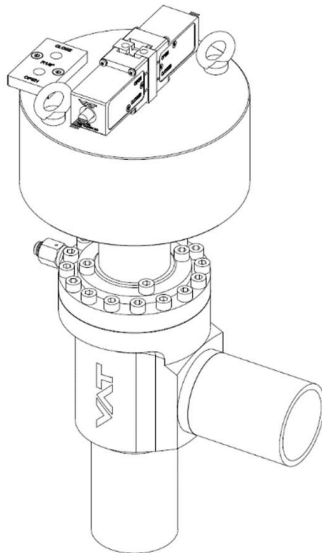

With ITER flanges

57036-XE21-AJF .

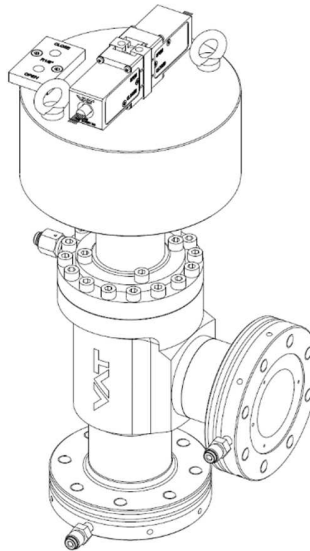

With KF flanges

57132-KE21-AJO .

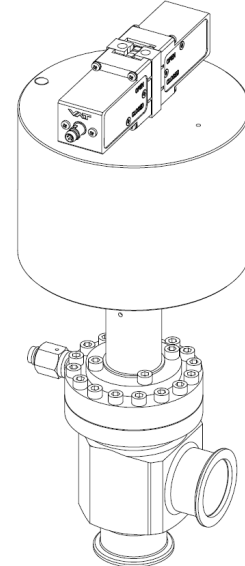

Sample picture

Imprint

Manufacturer VAT Vakuumentile AG, CH-9469 Haag, Switzerland

Website: www.vatvalve.com

Phone: +41 81 771 61 61

Fax: +41 81 771 48 30

Email: CH@vatvalve.com

Publisher VAT Vakuumentile AG, CH-9469 Haag, Switzerland

Editor VAT Vakuumentile AG, CH-9469 Haag, Switzerland

Print VAT Vakuumentile AG, CH-9469 Haag, Switzerland

Copyright © VAT Vakuumentile AG 2022

No part of these instructions may be reproduced in any way (photocopies, microfilms or any other reproduction processes) nor may it be manipulated with electronic systems, duplicated or distributed without written permission from VAT. Offenders are liable to pay damages.

The original VAT firmware and updated state of the art versions of the VAT firmware are intended for use with VAT products. The VAT firmware contains a limited, time unlimited user license. The VAT firmware may not be used for purposes other than those intended nor is it permitted to make copies of the VAT firmware. In particular, it is strictly forbidden to give copies of the VAT firmware to other people.

The use of trade names, brand names, trademarks, etc. in these Instructions does not entitle third parties to consider these names to be unprotected and to use them freely. This is in accordance with the meaning of the laws and acts covering brand names and trademarks.

Contents

1	Description of product	4
1.1	Identification of product.....	4
1.2	Use of product.....	4
1.3	Related documents.....	4
1.4	Important information.....	4
1.5	Technical data.....	4
2	Safety	5
2.1	Compulsory reading material.....	5
2.2	Danger levels.....	5
2.3	Personnel qualifications.....	6
2.4	Safety labels.....	6
3	Design and Function	7
3.1	Design.....	7
3.2	Function.....	8
4	Installation	9
4.1	Unpacking.....	9
4.2	Installation into the system.....	11
4.2.1	Preparation for installation.....	11
4.2.2	Mounting to the system.....	13
4.3	Compressed air connection.....	14
5	Operation	15
5.1	Normal operation.....	15
5.2	Operation under increased temperature.....	16
5.3	Bake-out.....	16
5.4	Behavior in case of air pressure drop.....	16
5.5	Behavior in case of power failure.....	16
6	Trouble shooting	17
7	Maintenance	18
7.1	Maintenance intervals.....	18
7.2	Replacement of dynamic seal VATRING.....	19
8	Repairs	23
9	Dismounting and Storage	24
9.1	Dismounting.....	24
9.2	Storage.....	25
10	Packaging and Transport	26
10.1	Packaging.....	27
10.2	Transport.....	27
11	Disposal	28
12	Spare parts	29

1 Description of product

1.1 Identification of product

The fabrication number is lasered or etched directly on the product.



XXXX-XXXX-XXXX/XXXX ← Fabrication number

Made in Switzerland

1.2 Use of product

Use product for clean and dry vacuum applications only. Other applications are only allowed with the written permission of VAT. Suitable for XHV applications..

1.3 Related documents

- Product data sheet
- Dimensional drawing

1.4 Important information



This symbol points to a very important statement that requires particular attention.

Example:



VAT disclaims any liability for damages resulting from inappropriate packaging.

1.5 Technical data

See product data sheet and dimensional drawing.

2 Safety

2.1 Compulsory reading material

Read this chapter prior to performing any work with or on the product. It contains important information that is significant for your own personal safety. This chapter must have been read and understood by all persons who perform any kind of work with or on the product during any stage of its serviceable life.

	NOTICE
	<p>Lack of knowledge Failing to read this manual may result in property damage. Firstly, read manual.</p>





These Installation, Operating & Maintenance Instructions are an integral part of a comprehensive documentation belonging to a complete technical system. They must be stored together with the other documentation and accessible for anybody who is authorized to work with the system at any time.

2.2 Danger levels



	⚠ DANGER
	<p>High risk Indicates a hazardous situation which, if not avoided, will result in death or serious injury.</p>

	⚠ WARNING
	<p>Medium risk Indicates a hazardous situation which, if not avoided, could result in death or serious injury.</p>

	⚠ CAUTION
	<p>Low risk Indicates a hazardous situation which, if not avoided, may result in minor or moderate injury.</p>

	NOTICE
	<p>Command Indicates a hazardous situation which, if not avoided, may result in property damage.</p>

2.3 Personnel qualifications

	 WARNING
	<p>Unqualified personnel Inappropriate handling may cause serious injury or property damage. Only qualified personnel are allowed to carry out the described work.</p>

2.4 Safety labels

Label	Part No.	Location on valve
	T-9001-155	On protective covers of flanges

Table 2-1

3 Design and Function

3.1 Design

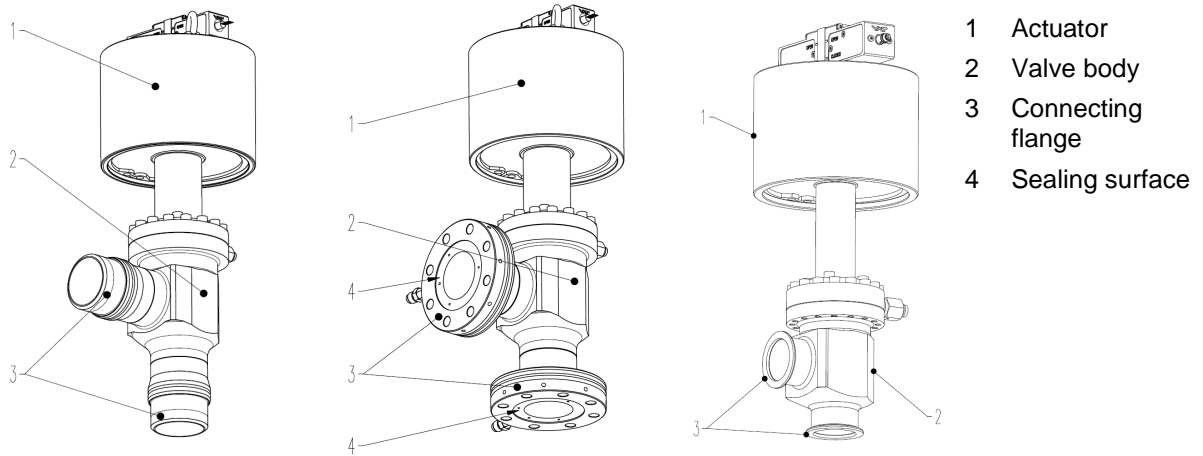

Figure 3-1

3.2 Function

Valve is closed by a spring. Valve is opened pneumatically.

Closing:

The valve plate moves towards the seat. The VATRING (1) moves into the valve seat and closes leaktight.

Opening:

The valve plate moves back from the seat until the open stop is reached.

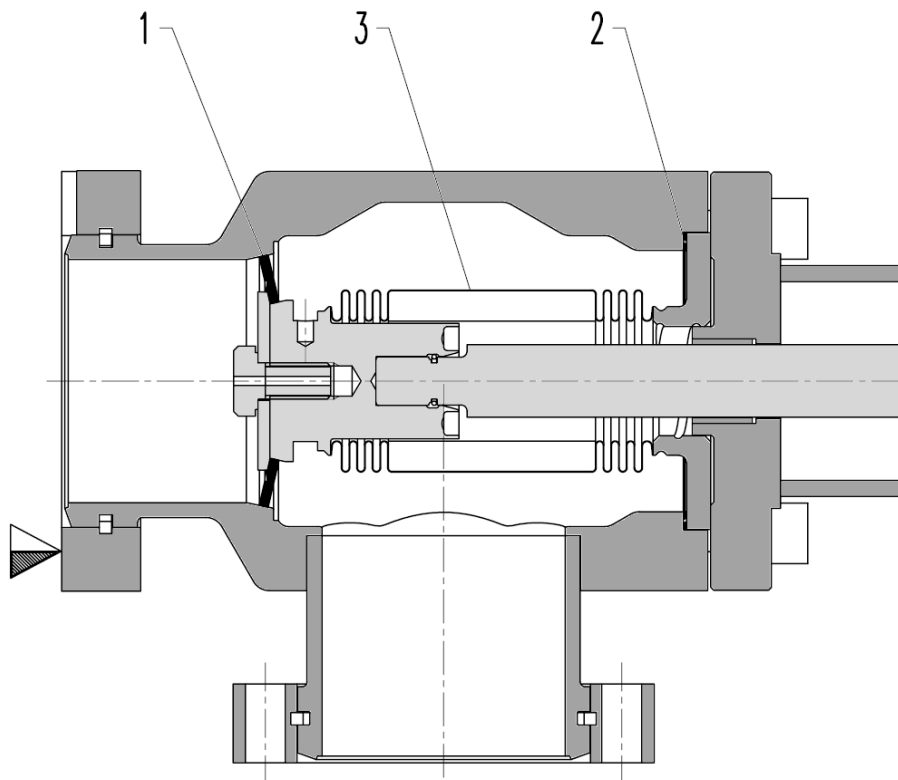



Figure 3-2 (sample picture)

- 1 VATRING
- 2 Bonnet seal
- 3 Bellows

- ▼ Valve seat side

4 Installation

	⚠ WARNING
	<p>Unqualified personnel Inappropriate handling may cause serious injury or property damage. Only qualified personnel are allowed to carry out the described work.</p>

4.1 Unpacking



- Make sure that the supplied products are in accordance with your order.
- Inspect the quality of the supplied products visually. If it does not meet your requirements, please contact VAT immediately.
- Store the original packaging material. It may be useful if products must be returned to VAT.



Don't open the plastic bag before mounting into the system.

	NOTICE
	<p>Wrong lifting Valve may crash and get damaged. Use only the eyebolts shown in the dimensional drawing and in «Figure 4-1» on page 10 to lift the valve. Using any other components (e. g. position indicators, solenoids etc.) to lift the valve is strictly forbidden.</p>

	NOTICE
	<p>Sensitive product Valve parts may get damaged.</p> <ul style="list-style-type: none"> – When lifting the valve, pay attention that the valve does not touch any solid objects. – Lift valve carefully and put it down on a clean surface or mount it to a clean system.

Using a crane for lifting the valve out of the transport box is recommended; see «Figure 4-1».

Weight of valves; see chapter «1.5 Technical data».

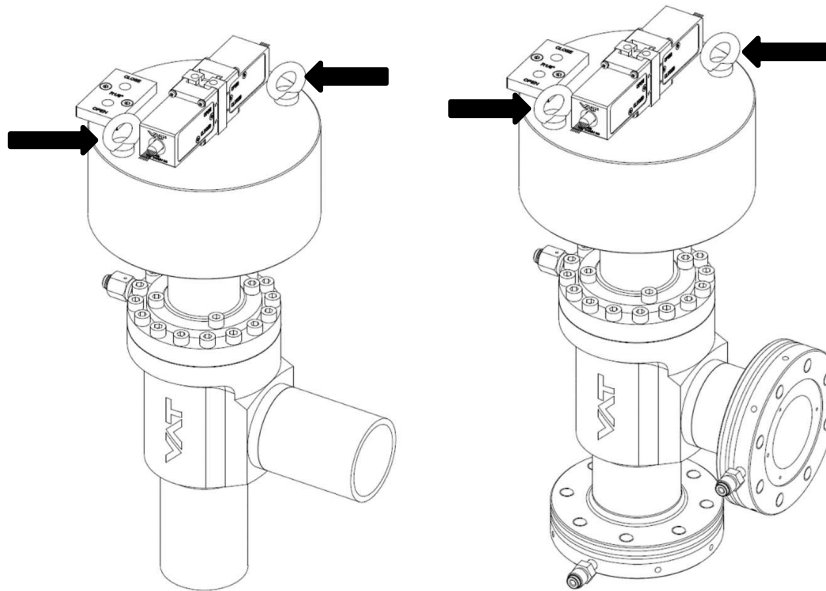





Figure 4-1

4.2 Installation into the system

	⚠ WARNING
	<p>Movable parts</p> <p>Human body parts may get jammed and severely injured.</p> <p>Do not connect or supply electrical power and compressed air before the product is completely mounted in the system.</p>

	NOTICE
	<p>Contamination</p> <p>Product may get contaminated.</p> <p>Always wear cleanroom gloves when handling the product.</p>

	NOTICE
	<p>Force effect from other components of the system</p> <p>Valve body may get deformed and/or malfunctions may occur.</p> <ul style="list-style-type: none"> – Do not use valve to support other components. – Make sure that forces from other components do not impair the valve; use bellows sections, for instance.

4.2.1 Preparation for installation

	⚠ WARNING
	<p>Danger of injury in case of insufficient skills</p> <p>Inappropriate handling may cause serious injury or property damage.</p> <p>Make sure that the valve does not topple or fall down while removing the protective covers from the flanges.</p>

	NOTICE
	<p>Sensitive product</p> <p>Valve parts may get damaged.</p> <p>When removing the protective covers from the flanges, be careful to avoid damage to the valve.</p>

1. Remove plastic bag.
2. Remove nuts, bolts and protective covers (1).

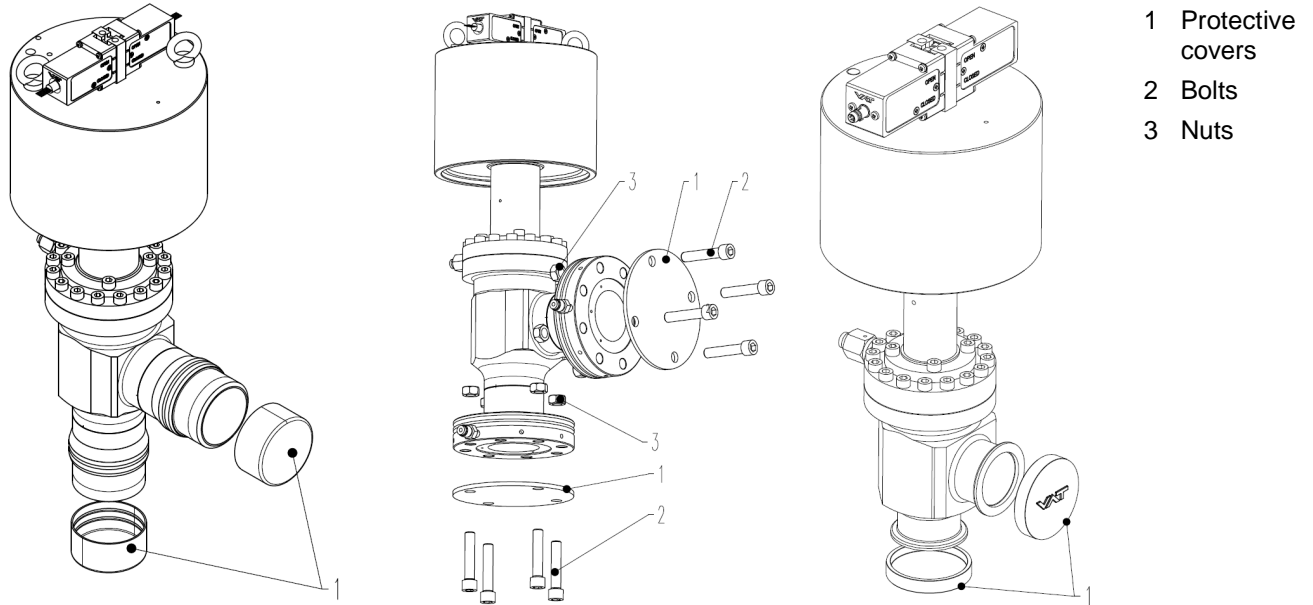

Figure 4-2



Store protective covers, bolts and nuts. They may be useful when valve needs to be repacked.

3. Clean sealing surfaces; see «Figure 3-1» on page 7, with cleanroom wiper soaked with pure alcohol (Isopropanol).
4. Clean sealing surface with clean, oil free compressed air.

4.2.2 Mounting to the system

1. Mount valve to your system by using appropriate flange screws (different quantity of screws required – depending on valve size).
2. Mount screws evenly in crosswise order until the seal touches the sealing surface.
3. Tighten all screws with the torques appropriate for the property classes of the screws. Apply the torque gradually and in crosswise order.

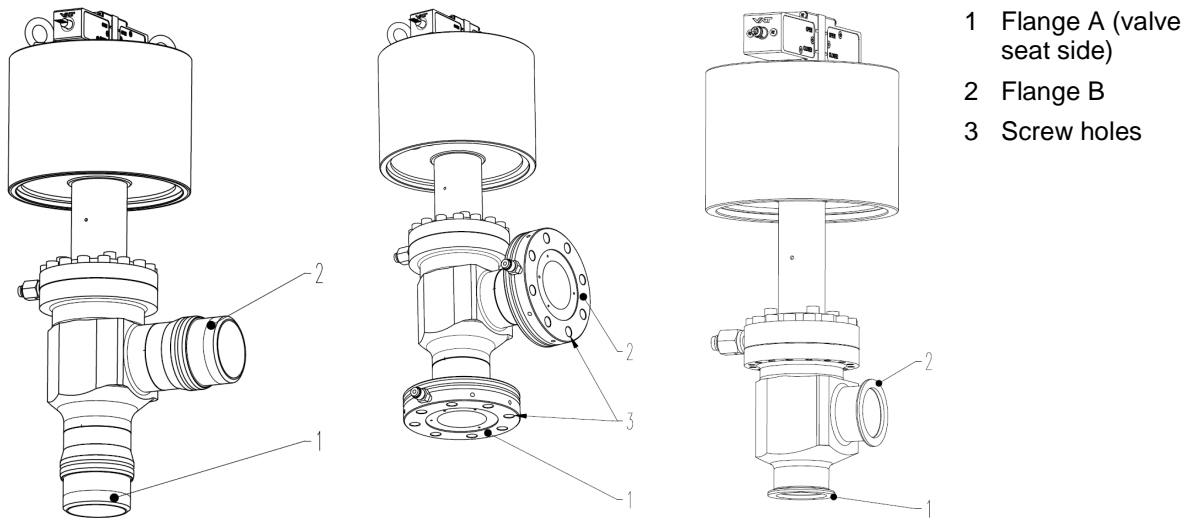

Figure 4-3

4.3 Compressed air connection

	⚠ WARNING
	<p>Valve in open position</p> <p>Risk of injury when compressed air is connected to the valve.</p> <p>Connect compressed air only when:</p> <ul style="list-style-type: none"> - valve is installed in the vacuum system - moving parts cannot be touched

	NOTICE
	<p>Wrong sequence of connections</p> <p>Valve mechanism may get damaged when electrical power is being connected before compressed air is connected.</p> <p>Always connect compressed air before connecting electrical power.</p>



Use clean, dry or slightly oiled air only.



Admissible air pressure range, see product data sheet.

1. Connect compressed air according to the product data sheet and dimensional drawing.



Ordering numbers: 57 ... - . E21 without solenoid valve , with position indicator

5 Operation

	⚠ WARNING
	<p>Unqualified personnel Inappropriate handling may cause serious injury or property damage. Only qualified personnel are allowed to carry out the described work.</p>

	⚠ WARNING
	<p>Movable parts Human body parts may get jammed and severely injured. Do not operate before product is installed completely into the vacuum system.</p>

5.1 Normal operation

Valve is opened with compressed air. Valve is spring closed.



For technical details, see product data sheet.

Action	Execution	Procedure
To open the valve	Without solenoid valve 57 ... - . E21-	Afterwards, supply admissible compressed air to connection ☉ OPEN and release air through connection ☉ CLOSE.

Table 5-1

Action	Execution	Procedure
To close the valve	Without solenoid valve 57 ... - . E21-	Afterwards, supply admissible compressed air to connection ☉ CLOSE and release air through connection ☉ OPEN.

Table 5-2

5.2 Operation under increased temperature

Maximum allowed temperature see product data sheet.

NOTICE	
	<p>Inconstant temperatures</p> <p>Performance of the valve may deteriorate.</p> <ul style="list-style-type: none">– Actuate valve only after the bake-out temperature has been stable for two hours.– If valve must be actuated during bake-out, make sure that the heating or cooling rate does not exceed 10 °C per hour in the temperature range from 200°C to 350 °C– Make sure that the temperature differences over the whole body do not exceed 30 °C.

5.3 Bake-out

See product data sheet.

5.4 Behavior in case of air pressure drop

See product data sheet.

5.5 Behavior in case of power failure

See product data sheet.

6 Trouble shooting

Failure	Check	Action	See
Valve mechanism does not move	Compressed air	Connect compressed air	«4.3 Compressed air connection»
	Operating pressure	Adjust operating pressure	«4.3 Compressed air connection»
Leak at gate	Condition of gate seal	Please contact VAT	www.vatvalve.com
	Operating pressure	Adjust operating pressure	«4.3 Compressed air connection»
Leak at body	Condition of bonnet seal and sealing surface	Please contact VAT	www.vatvalve.com
	Condition of bellows	Please contact VAT	www.vatvalve.com

Table 6-1

If you need any further information, please contact one of our service centers. You will find the addresses on our website www.vatvalve.com.

7 Maintenance

7.1 Maintenance intervals

Under clean operating conditions the valve does not require any maintenance during specified lifetime.



- Impacts from the process may require more frequent maintenance.
- When the valve has reached the specified lifetime; see product data sheet, we recommend to have it serviced by VAT. Please contact your nearest VAT service center to get recommendations and an offer. You will find the addresses on our website www.vatvalve.com.

7.2 Replacement of dynamic seal VATRING

In case of a seat seal leak caused by environmental influences and no visible damage of the sealing surface at the seat, the VATRING seal can be replaced. VAT offers a range of components; see «Table 12-1» on page 29 for further contact information. The seal exchange could be carried out by the user.

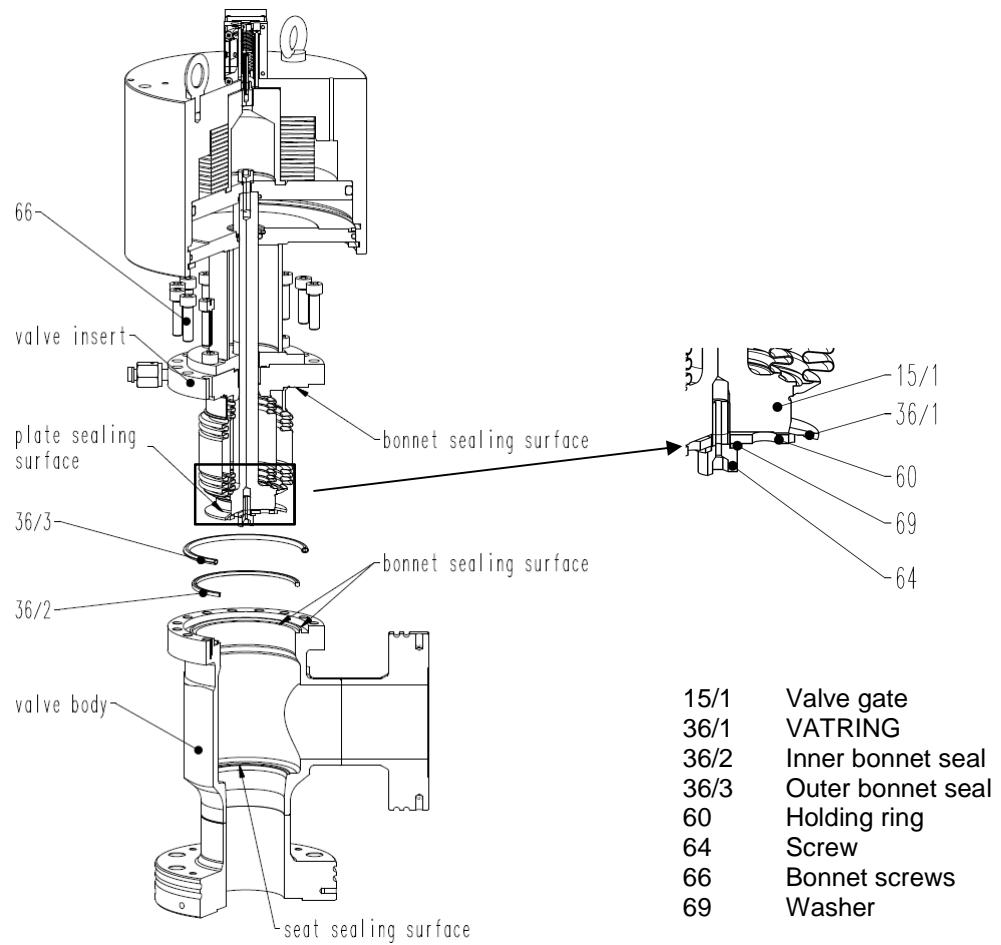



Figure 7-1

Required material: VATRING

Ordering information: See chapter «12 Spare parts» on page 29 and «Figure 7-1» on page 19.

NOTICE	
	<p>Inappropriate mounting position of valve</p> <p>Maintenance may be troublesome and parts may drop down.</p> <p>Ideally dismount valve from the system and put it on a clean workbench with the actuator upwards.</p>

Procedure:

The item numbers in brackets refer to; see «Figure 7-1» on page 19.

1. Open valve with compressed air and keep it open (leave compressed air pressure on) while replacing the VATRING
2. Remove the bonnet screws (66).
3. Pull valve insert carefully out of the valve body without touching the body wall. Touching the body wall may cause severe damage to delicate parts of the insert.
4. Remove bonnet seal (36/2 and 36/3).
5. Clean sealing surfaces of bonnet and seat of valve body with pure alcohol (Isopropanol).



Make sure that the sealing surface is free of scratches.



When loosening and tightening the screw (64) protect the bellows against torsion by hole or wrench size; see «Figure 7-2» on page 21.

6. Remove the screw (64).
7. Remove holding ring (60).
8. Remove VATRING (36/1).
9. Clean sealing surface of plate (15/1) with pure alcohol (Isopropanol), use a cleanroom wiper.



Make sure that the sealing surface is free of scratches.

10. Put new VATRING (36/1) on sealing surface of plate (15/1).



Make sure that the seal ring is installed in the correct direction.

11. Put holding ring (60) on plate (15/1).
12. Insert screw (64) and tighten them slightly only.
13. Level out VATRING (36/1) and plate (15/1) along the whole circumference. Height difference shall not exceed 0.1 mm. Check height difference accurately at four spots (measured angle 90°) around the whole circumference.

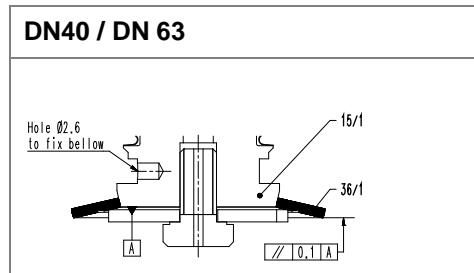

Figure 7-2

14. Clean sealing surfaces of bonnet and seat of valve body with pure alcohol (Isopropanol), use cleanroom wiper.
15. Protect bellows against torsion by hole or wrench size; see «Figure 7-2» and tighten screw (64) with the following torque:

DN 40: 7 Nm
 DN 63: 15 Nm

16. Put bonnet seals (36/2 and 36/3) on sealing surface of valve body.

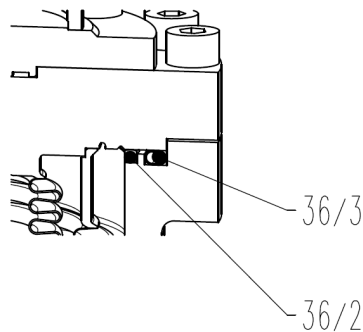

Figure 7-3



Make sure that the seal rings are installed in the correct direction.

17. Move valve insert (in open secured position) carefully into the valve without touching the body wall. Touching the body wall may cause severe damage to delicate parts of the insert.

18. Insert all bonnet screws (66) and tighten all screws gradually in crosswise order with the following torque:

DN 40: 7 Nm
DN 63: 15 Nm

19. Install valve to your system.





Valve is ready to use.

8 Repairs

Repairs may only be carried out by the VAT service staff. In exceptional cases, the customer is allowed to carry out the repairs, but only with the prior consent of VAT.

Please contact one of our service centers. You will find the addresses on our website www.vatvalve.com.

9 Dismounting and Storage

	<p style="text-align: center;">WARNING</p> <p>Unqualified personnel Inappropriate handling may cause serious injury or property damage. Only qualified personnel are allowed to carry out the described work.</p>
	<p style="text-align: center;">WARNING</p> <p>Hazardous components Human body parts may get jammed and severely injured. Before dismantling the product:</p> <ul style="list-style-type: none"> - disconnect compressed air supply - disconnect electrical power supply
	<p style="text-align: center;">WARNING</p> <p>Movable parts Human body parts may get jammed and severely injured. Keep human body parts away from movable parts.</p>
	<p style="text-align: center;">NOTICE</p> <p>Contamination Product may get contaminated. Always wear cleanroom gloves when handling the product.</p>

9.1 Dismounting

1. Close the valve.
2. Disconnect compressed air supply.

Dismount the valve according chapter 4 Installation on page 9, however in reverse order.



Observe safety instruction of chapter «2 Safety».

9.2 Storage

NOTICE	
	<p>Wrong storage</p> <p>Inappropriate temperatures and humidity may cause damage to the product.</p> <p>Valve must be stored at:</p> <ul style="list-style-type: none">– relative humidity between 10% and 70%– temperature between +10 °C and +50 °C– non-condensing environment

NOTICE	
	<p>Inappropriate packaging</p> <p>Product may get damaged if inappropriate packaging material is used.</p> <p>Always use the original packaging material and handle product with care.</p>

1. Clean / decontaminate valve.
2. Mount protective covers on flanges; see chapter «Figure 4-2».
3. Pack valve appropriately, by using the original packaging material.

10 Packaging and Transport

	WARNING
	Unqualified personnel Inappropriate handling may cause serious injury or property damage. Only qualified personnel are allowed to carry out the described work.

	WARNING
	Harmful substances Risk of injury in case of contact with harmful substances. Remove harmful substances (e. g. toxic, caustic or microbiological ones) from valve before you return the valve to VAT.

	NOTICE
	Inappropriate packaging Product may get damaged if inappropriate packaging material is used. Always use the original packaging material and handle product with care.



- When returning products to VAT, please fill out the VAT form «Declaration of Chemical Contamination» and send it to VAT in advance. The form can be downloaded from our website www.vatvalve.com.
- If products are radioactively contaminated, the VAT form «Contamination and Radiation Report» must be filled out. Please contact VAT in advance.
- If products are sent to VAT in contaminated condition, VAT will carry out the decontamination procedure at the customer's expense.

10.1 Packaging

	NOTICE
	<p>Valve in closed or in undefined position Valve mechanism may get damaged if valve is in close or undefined position. Make sure that the valve is in open position secured.</p>

1. Cover all valve openings with protective covers; see chapter «4.2.1 Preparation for installation».
2. Pack valve appropriately, by using the original packaging material.



VAT disclaims any liability for damages resulting from inappropriate packaging.

10.2 Transport

	NOTICE
	<p>Inappropriate packaging Product may get damaged if inappropriate packaging material is used. Always use the original packaging material and handle product with care.</p>



VAT disclaims any liability for damages resulting from inappropriate packaging.

11 Disposal

Observe the local regulations for disposal

	WARNING
	<p>Harmful substances Environmental pollution. Discard products and parts according to the local regulations.</p>

	WARNING
	<p>Unqualified personnel Inappropriate handling may cause serious injury or property damage. Only qualified personnel are allowed to carry out the disposal.</p>

	CAUTION
	<p>Risk of damage Indicates a hazardous situation which, if not avoided, may result in minor or moderate injury. A large number of diverse materials are used in the product. Some of them could cause human and machine damage in the case of improper handling.</p> <ul style="list-style-type: none"> • Observe local regulations in regard to waste disposal without fail. • Commission an authorized waste disposal company for the professional disposal of your waste.

	NOTICE
	<p>Improper disposal Some built-in materials can cause damage, if improperly handled. - When disposing, take into account all the different materials used</p>



- Hire an authorised waste disposal company to dispose of the waste in a professional manner.

The following list should help you to dismantle your product without making serious errors and to properly separate out the product scrap.

Material groups	Hazard level
non-ferrous metals	high
stainless steel	low
aluminium	low
plastics	medium
lubricants	high
electronic scrap	high
batteries	very high
cables and wires	medium
motors	medium
seals and rubber parts	high

12 Spare parts

	NOTICE
<p>Non-original spare parts Non-original spare parts may cause damage to the product. Use original spare parts from VAT only.</p>	



- Parts may only be replaced by the VAT service staff or specially trained service staff of the customer.
- Please contact one of our service centers and specify the fabrication number of the product; see chapter «1.1 Identification of product». You will find the addresses on our website www.vatvalve.com.

Description	Item	DN	Part No.	Quantity per valve	Repair procedure see chapter
VATRING	36/1	40	42372-01	1	7 Maintenance
		63	39615-01	1	
Bonnet seal	36/2	40	543311	1	
		63	543675	1	
	36/3	40	543304	1	
		63	543868	1	
Bonnet screws	69	40	N-5019-792	16	
		63	N-5019-817	16	

Table 12-1